

# The BERNINA Edition

by Amanda Greene / #82014 / 45 Designs





Note: Some designs in this collection may have been created using unique special stitches and/or techniques. To preserve design integrity when rescaling or rotating designs in your software, always rescale or rotate designs using the handles directly on-screen.



**82014-01 830 Record Appliqué**  
5.19 X 4.35 in.  
131.83 X 110.49 mm  
14,044 St. **L**



**82014-02 Virtuosa Appliqué**  
4.52 X 5.08 in.  
114.81 X 129.03 mm  
12,807 St. **L**



**82014-03 Nova Appliqué**  
4.84 X 4.31 in.  
122.94 X 109.47 mm  
13,149 St.

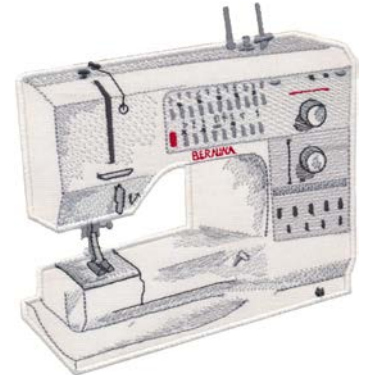

**82014-04 1230 Appliqué**  
5.04 X 5.53 in.  
128.02 X 140.46 mm  
15,323 St. **L**



**82014-05 1630 Appliqué**  
4.99 X 5.46 in.  
126.75 X 138.68 mm  
13,778 St. **L**



**82014-06 Activa 240 Appliqué**  
5.02 X 4.86 in.  
127.51 X 123.44 mm  
13,320 St. **L**

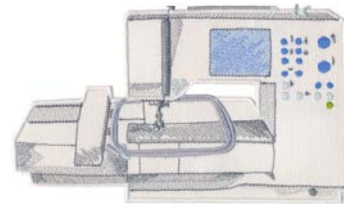

**82014-07 180 Appliqué**  
6.88 X 3.96 in.  
174.75 X 100.58 mm  
16,242 St. **L**

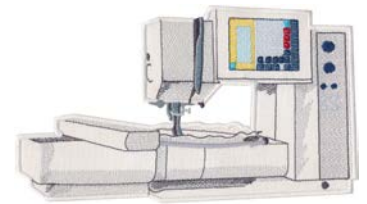

**82014-08 730 Appliqué**  
8.09 X 4.65 in.  
205.49 X 118.11 mm  
18,441 St. **L**



**82014-09 Aurora 430 Appliqué**  
5.00 X 4.57 in.  
127.00 X 116.08 mm  
15,231 St.



**82014-10 3 Series Appliqué**  
4.73 X 4.48 in.  
120.14 X 113.79 mm  
13,466 St.



**82014-11 570 Appliqué**  
4.58 X 4.27 in.  
116.33 X 108.46 mm  
13,018 St.



**82014-12 790 Appliqué**  
5.91 X 4.93 in.  
150.11 X 125.22 mm  
15,457 St. **L**

**L** Design is larger than 5" (127 mm) in either direction.

**S** Design is smaller than 1.5" (38.1 mm) in either direction.

It is a violation of Copyright law to make and distribute copies of electronic designs or artwork. Electronic designs are licensed to the original purchaser for use at one location. ©2015 OESD, LLC. All rights reserved.

Note: Some designs in this collection may have been created using unique special stitches and/or techniques. To preserve design integrity when rescaling or rotating designs in your software, always rescale or rotate designs using the handles directly on-screen.

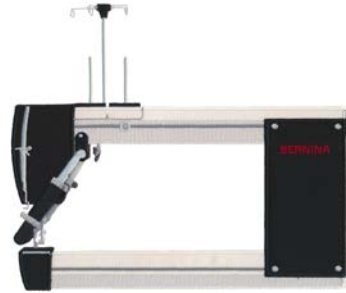

**82014-13 880 Appliqué**  
10.18 X 4.95 in.  
258.57 X 125.73 mm  
25,026 St. **L**

**82014-14 Klasse Appliqué**  
5.60 X 5.06 in.  
142.24 X 128.52 mm  
15,160 St. **L**

**82014-15 Q Series Appliqué**  
8.79 X 7.32 in.  
223.27 X 185.93 mm  
23,280 St. **L**

**82014-16 Old Fashion Bernina Swirl Logo**  
5.05 X 3.31 in.  
128.27 X 84.07 mm  
11,803 St. **L**

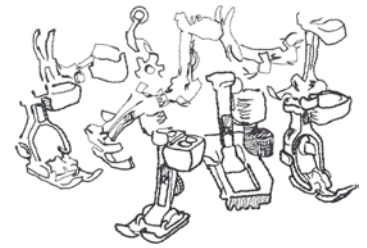
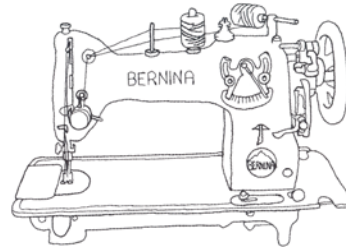
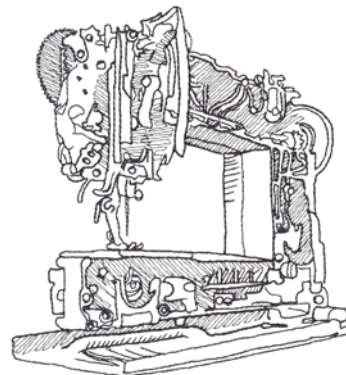
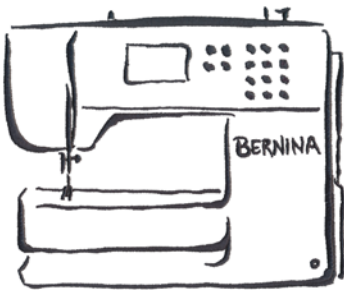

**82014-17 Brushstroke Machine**  
5.41 X 6.57 in.  
137.41 X 166.88 mm  
13,832 St. **L**

**82014-18 Naked Machine Sketch**  
4.36 X 4.81 in.  
110.74 X 122.17 mm  
11,635 St.

**82014-19 117**  
6.94 X 4.88 in.  
176.28 X 123.95 mm  
8,573 St. **L**

**82014-20 Presser Feet Sketch**  
4.78 X 3.35 in.  
121.41 X 85.09 mm  
7,845 St.



**82014-21 Bernina Factory Sketch**  
7.67 X 5.23 in.  
194.82 X 132.84 mm  
14,809 St. **L**

**82014-22 Toy Embroidery Machine**  
3.39 X 4.21 in.  
86.11 X 106.93 mm  
26,107 St.

**82014-23 Machine with Mountains**  
3.72 X 3.21 in.  
94.49 X 81.53 mm  
15,181 St.

**82014-24 Old Fashion Bernina Logo 1**  
7.73 X 4.27 in.  
196.34 X 108.46 mm  
23,239 St. **L**

**L** Design is larger than 5" (127 mm) in either direction.  
**S** Design is smaller than 1.5" (38.1 mm) in either direction.



Note: Some designs in this collection may have been created using unique special stitches and/or techniques. To preserve design integrity when rescaling or rotating designs in your software, always rescale or rotate designs using the handles directly on-screen.

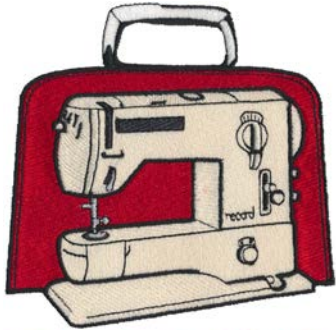

**BERNINA**

82014-25 Old Fashion Bernina Logo 2  
4.69 X 5.35 in.  
119.13 X 135.89 mm  
38,762 St. **L**



82014-26 Bernina Sign Appliqué  
6.63 X 3.94 in.  
168.40 X 100.08 mm  
8,494 St. **L**



82014-27 Bernina Dress Form Appliqué  
3.31 X 9.38 in.  
84.07 X 238.25 mm  
26,081 St. **L**



82014-28 Bernina Word Art Machine Appliqué  
5.57 X 4.61 in.  
141.48 X 117.09 mm  
27,231 St. **L**

**BERNINA**  
*made to create*

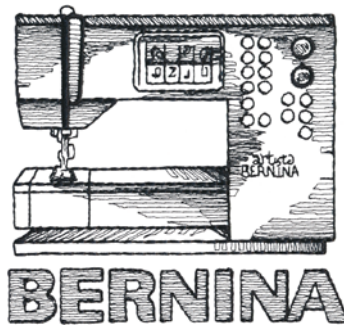

**BERNINA**

82014-29 Modern Bernina Logo  
7.43 X 2.04 in.  
188.72 X 51.82 mm  
14,545 St. **L**

82014-30 Bernina Machine  
3.82 X 3.53 in.  
97.03 X 89.66 mm  
8,771 St.



82014-31 Classic Bernina Patch Appliqué  
3.67 X 7.14 in.  
93.22 X 181.36 mm  
22,443 St. **L**



82014-32 Bernina Love Pincushion  
6.82 X 4.82 in.  
173.23 X 122.43 mm  
6,965 St. **L**

**NINA3BER**  
**BERNINA**  
**NA3BERNI**  
**INA3BERN**

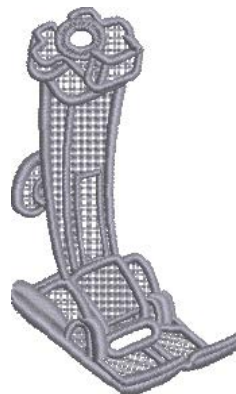

82014-33 Bernina Repeat Logo  
6.23 X 4.54 in.  
158.24 X 115.32 mm  
18,459 St. **L**

82014-34 Presser Foot FSL  
1.78 X 3.00 in.  
45.21 X 76.20 mm  
8,460 St.

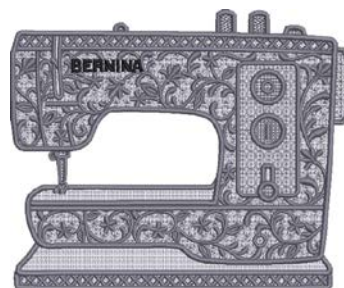

82014-35 830 Record FSL  
6.26 X 5.13 in.  
159.00 X 130.30 mm  
71,171 St. **L**

**BERNINA**

82014-36 Bernina FSL  
7.64 X 1.31 in.  
194.06 X 33.27 mm  
26,656 St. **LS**

**L** Design is larger than 5" (127 mm) in either direction.  
**S** Design is smaller than 1.5" (38.1 mm) in either direction.

Note: Some designs in this collection may have been created using unique special stitches and/or techniques. To preserve design integrity when rescaling or rotating designs in your software, always rescale or rotate designs using the handles directly on-screen.



82014-37 Bobbin FSL  
1.82 X 1.82 in.  
46.23 X 46.23 mm  
5,255 St.

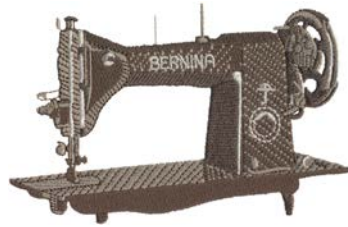

82014-38 105  
5.43 X 3.50 in.  
137.92 X 88.90 mm  
26,141 St. **L**

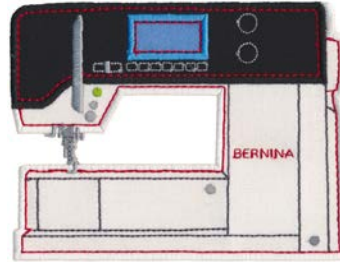

82014-39 580 Appliqué  
5.42 X 4.15 in.  
137.67 X 105.41 mm  
13,990 St. **L**

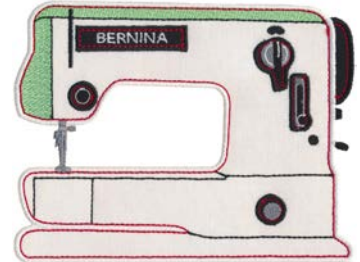

82014-40 730 Appliqué  
6.24 X 4.80 in.  
158.50 X 121.92 mm  
21,246 St. **L**



82014-41 105 with Mountain  
5.14 X 5.25 in.  
130.56 X 133.35 mm  
37,187 St. **L**



82014-42 Swiss Heritage  
3.43 X 3.37 in.  
87.12 X 85.60 mm  
13,595 St.



82014-43 Sew Like A Rock Star  
5.36 X 6.21 in.  
136.14 X 157.73 mm  
20,803 St. **L**



82014-44\_PW BERNINA Made to Create PaintWork  
2.05 X 7.40 in.  
52.07 X 187.96 mm  
**L**



82014-45\_CR BERNINA  
CrystalWork  
.96 X 7.07 in.  
24.38 X 179.58 mm  
**L S**

**L** Design is larger than 5" (127 mm) in either direction.  
**S** Design is smaller than 1.5" (38.1 mm) in either direction.

It is a violation of Copyright law to make and distribute copies of electronic designs or artwork. Electronic designs are licensed to the original purchaser for use at one location. ©2015 OESD, LLC. All rights reserved.

Listings below indicate color sample, stitching order and suggested thread color number. Most numbers indicate Isacord thread. However, colors beginning with 20501 refer to YLI Fine Metallics, 7 refer to Yenmet Metallic, 8 refer to YLI Variations Variegated Thread and 9 refer to Isacord Multicolor Variegated.

### 82014-01 830 Record Appliqué

□	1. Machine Placement Stitch.....	0015
□	2. Cut Line & Tackdown .....	0015
■	3. Silver Shading .....	3971
■	4. Dark Silver Shading .....	0131
□	5. Machine Cover Stitch .....	0015
■	6. Gray Outlines & Detail .....	3274
■	7. Light Gray Detail .....	3770
■	8. Thread .....	1902
■	9. Charcoal Letters & Detail .....	4174
■	10. Medium Gray Side Knob .....	0108

### 82014-02 Virtuosa Appliqué

□	1. Machine Placement Stitch.....	0015
□	2. Cut Line & Tackdown .....	0015
■	3. Silver Shading .....	3971
■	4. Dark Silver Shading .....	0131
■	5. Blue Letters .....	3762
□	6. Machine Cover Stitch .....	0015
■	7. Light Yellow Screen .....	0713
■	8. Charcoal Outlines & Detail .....	4174
■	9. Buttons .....	3711
■	10. Medium Silver Detail .....	0105
□	11. White Detail .....	0015
■	12. Letters .....	1902

### 82014-03 Nova Appliqué

□	1. Machine Placement Stitch.....	0015
□	2. Cut Line & Tackdown .....	0015
■	3. Medium Silver Shading .....	0105
■	4. Medium Gray Shading .....	4073
□	5. Machine Cover Stitch .....	0015
■	6. Red Detail .....	1902
□	7. White Detail .....	0015
■	8. Red Knob Detail .....	1902
■	9. Dark Red Knob Detail .....	1912
■	10. Silver Foot .....	3971
■	11. Charcoal Detail .....	4174

### 82014-04 1230 Appliqué

□	1. Machine Placement Stitch.....	0015
□	2. Cut Line & Tackdown .....	0015
□	3. Machine Cover Stitch .....	0015
■	4. Silver Shading .....	3971
■	5. Dark Silver Shading .....	0131
■	6. Gray Detail .....	3274
■	7. Red Letters & Detail .....	1902
■	8. Charcoal Detail .....	4174

### 82014-05 1630 Appliqué

□	1. Machine Placement Stitch.....	0015
□	2. Cut Line & Tackdown .....	0015
■	3. Silver Shading .....	3971
□	4. Machine Cover Stitch .....	0015
■	5. Screen .....	5832
■	6. Letters .....	1902
■	7. Dark Silver Shading .....	0131
■	8. Gray Outlines & Detail .....	3274
■	9. Light Blue Detail .....	4071

### 82014-06 Activa 240 Appliqué

□	1. Machine Placement Stitch.....	0015
□	2. Cut Line & Tackdown .....	0015
■	3. Silver Shading .....	3971
■	4. Dark Silver Shading & Outlines .....	0131
□	5. Machine Cover Stitch .....	0015
■	6. Screen .....	0741
■	7. Screen Highlights .....	0713
■	8. Red Detail .....	1902
□	9. White Detail .....	0015
■	10. Gray Detail .....	3274

### 82014-07 180 Appliqué

□	1. Machine Placement Stitch.....	0015
□	2. Cut Line & Tackdown .....	0015
■	3. Silver Shading .....	3971
■	4. Dark Silver Shading .....	0131
□	5. Machine Cover Stitch .....	0015
■	6. Hoop .....	3572
■	7. Light Blue Detail .....	4071
■	8. Blue Screen .....	3652
■	9. Medium Blue Screen Shading .....	3630
■	10. Dark Blue Detail .....	3713
■	11. Gray Linework .....	3274
■	12. Green Detail .....	5912

### 82014-08 730 Appliqué

□	1. Machine Placement Stitch.....	0015
□	2. Cut Line & Tackdown .....	0015
■	3. Silver Shading .....	3971
■	4. Medium Silver Detail .....	0105
■	5. Dark Silver Shading .....	0131
□	6. Machine Cover Stitch .....	0015
■	7. Medium Gray Detail .....	4073
■	8. Embroidery Hoop .....	3572
■	9. Light Charcoal Shading & Outlines .....	0132
■	10. Sky Blue Screen Detail .....	3962
■	11. Pale Blue Detail .....	3650
■	12. Yellow Detail .....	0504
■	13. Aqua Blue Detail .....	4122
■	14. Dark Blue Detail .....	4133
■	15. Red Detail .....	1902
■	16. Light Blue Detail .....	4071

### 82014-09 Aurora 430 Appliqué

□	1. Machine Placement Stitch.....	0015
□	2. Cut Line & Tackdown .....	0015
■	3. Silver Shading .....	3971
■	4. Panel Shading .....	0151
□	5. Machine Cover Stitch .....	0015
■	6. Medium Gray Shading .....	0131
■	7. Light Blue Screen .....	3650
■	8. Aqua Blue Detail .....	4133
□	9. White Detail .....	0015
■	10. Light Charcoal Outlines .....	0132
■	11. Letters .....	1902

### 82014-10 3 Series Appliqué

□	1. Machine Placement Stitch.....	0015
□	2. Cut Line & Tackdown .....	0015
■	3. Silver Detail .....	3971
■	4. Light Gray Shading .....	0145
□	5. Machine Cover Stitch .....	0015
■	6. Dark Silver Shading & Detail .....	0131
■	7. Gray Detail .....	3274
■	8. Charcoal Detail .....	4174
■	9. Off White Detail .....	0101
■	10. Letters .....	1902

### 82014-11 570 Appliqué

□	1. Machine Placement Stitch.....	0015
□	2. Cut Line & Tackdown .....	0015
■	3. Light Gray Tackdown .....	0145
■	4. Silver Shading .....	3971
□	5. Machine Cover Stitch .....	0015
■	6. Dark Silver Detail & Shading .....	0131
■	7. Gray Linework .....	3274
■	8. Light Blue Detail .....	3962
■	9. Charcoal Detail .....	4174
■	10. Light Gray Detail .....	3770
■	11. Letters .....	1902

### 82014-12 790 Appliqué

□	1. Machine Placement Stitch.....	0015
□	2. Cut Line & Tackdown .....	0015
■	3. Silver Detail .....	3971
□	4. Machine Cover Stitch .....	0015
■	5. Black Panel Placement Stitch .....	0020
■	6. Cut Line & Tackdown .....	0020
■	7. Panel Cover Stitch .....	0020
■	8. Dark Silver Shading .....	0131
■	9. Gray Detail .....	3274
■	10. Screen .....	3650
■	11. Charcoal Detail .....	4174
■	12. Black Detail .....	0020
□	13. White Winder & Spool Bar Detail .....	0015
■	14. Letters .....	1902

### 82014-13 880 Appliqué

□	1. Machine Placement Stitch.....	0015
□	2. Cut Line & Tackdown .....	0015
■	3. Silver Shading .....	3971
■	4. Dark Silver Shading .....	0131
□	5. Machine Cover Stitch .....	0015
■	6. Hoop .....	3852
■	7. Gray Detail .....	3274
■	8. Light Blue Screen .....	3630
■	9. Dark Blue Shading .....	3810
■	10. Black Detail .....	0020
■	11. Medium Blue Detail .....	3572
■	12. Gray Detail .....	0105
■	13. Red Detail .....	1902

### 82014-14 Klasse Appliqué

■	1. Charcoal Detail .....	4174
□	2. Machine Placement Stitch.....	0015
□	3. Cut Line & Tackdown .....	0015
■	4. Silver Shading .....	3971
□	5. Machine Cover Stitch .....	0015
■	6. Dark Silver Shading .....	0131
■	7. Gray Detail .....	3274
■	8. Charcoal Detail .....	4174
□	9. Light Blue Detail .....	4071
■	10. Letters .....	5722

### 82014-15 Q Series Appliqué

□	1. Machine Placement Stitch.....	0015
□	2. Cut Line & Tackdown .....	0015
□	3. Machine Cover Stitch .....	0015
■	4. Silver Detail .....	3971
■	5. Gray Detail .....	3274
■	6. Black Panels Placement Stitch .....	0020
■	7. Cut Line & Tackdown .....	0020
■	8. Black Panels Cover Stitch .....	0020
■	9. Dark Silver Detail .....	0131
■	10. Black Detail .....	0020
■	11. Silver Detail .....	3971
□	12. Light Blue Detail .....	4071
■	13. Light Charcoal Detail .....	0132
■	14. Letters .....	1902

### 82014-16 Old Fashion Bernina Swirl Logo

■	1. Single Color Design .....	5415
---	------------------------------	------

### 82014-17 Brushstroke Machine

■	1. Single Color Design .....	4174
---	------------------------------	------

### 82014-18 Naked Machine Sketch

■	1. Single Color Design .....	4174
---	------------------------------	------

### 82014-19 117

■	1. Single Color Design .....	4174
---	------------------------------	------

### 82014-20 Presser Feet Sketch

■	1. Single Color Design .....	4174
---	------------------------------	------



Listings below indicate color sample, stitching order and suggested thread color number. Most numbers indicate Isacord thread. However, colors beginning with 20501 refer to YLI Fine Metallics, 7 refer to Yenmet Metallic, 8 refer to YLI Variations Variegated Thread and 9 refer to Isacord Multicolor Variegated.

## 82014-21 Bernina Factory Sketch

■ 1. Single Color Design .....	4174
--------------------------------	------

## 82014-22 Toy Embroidery Machine

■ 1. Red Inner Case .....	1800
■ 2. Inner Case Shading .....	2101
□ 3. White Inner Case Bottom .....	0015
■ 4. Machine .....	0670
■ 5. Machine Shading .....	0870
■ 6. Machine Base .....	0532
■ 7. Light Brown Machine Shading .....	0873
■ 8. Machine Outlines .....	0776
■ 9. Thread & Spool Pad .....	1753
■ 10. Light Gray Detail .....	3770
■ 11. Thread Shading .....	1902
■ 12. Charcoal Detail .....	4174
■ 13. Green Case .....	5633
■ 14. Dark Green Shading & Detail .....	5643
■ 15. Silver Detail .....	3971
■ 16. Dark Silver Detail & Shading .....	0131
■ 17. Handle .....	0945

## 82014-23 Machine with Mountains

□ 1. Light Blue on Mountain .....	4071
■ 2. Blue on Mountain .....	3641
■ 3. Dark Blue on Mountain .....	3644
■ 4. Medium Blue Shading .....	3654
■ 5. Off White Machine .....	0670
■ 6. Machine Shading .....	0660
■ 7. Light Gray Metal Parts .....	0105
■ 8. Dark Gray Detail .....	0132
■ 9. Machine Outlines & Detail .....	4073

## 82014-24 Old Fashion Bernina Logo 1

■ 1. Single Color Design .....	1902
--------------------------------	------

## 82014-25 Old Fashion Bernina Logo 2

□ 1. Handle .....	0015
■ 2. Red Detail .....	1902
■ 3. Charcoal Detail .....	4174
■ 4. Sewing Machine .....	0870
■ 5. Medium Silver Detail .....	0105
■ 6. Black Detail .....	0020

## 82014-26 Bernina Sign Appliqué

□ 1. Background Placement Stitch .....	0015
□ 2. Cut Line & Tackdown .....	0015
□ 3. Design & Cover Stitch .....	0015

## 82014-27 Bernina Dress Form Appliqué

■ 1. Top & Legs .....	4174
■ 2. Form Placement Stitch .....	1902
■ 3. Cut Line & Tackdown .....	1902
■ 4. Bobbins .....	3971
■ 5. Bobbin Outlines .....	0131
■ 6. Dark Red Details .....	1912
■ 7. Black Letters & Details .....	0020
□ 8. White Letters & Detail .....	0015
■ 9. Form Cover Stitch .....	1902

## 82014-28 Bernina Word Art Machine Appliqué

■ 1. Machine Placement Stitch .....	0105
■ 2. Cut Line & Tackdown .....	0105
■ 3. Cover Stitch & Detail .....	0105
■ 4. Black Words .....	0020
■ 5. Dark Gray Words .....	4073
■ 6. Red Detail & Words .....	1902

## 82014-29 Modern Bernina Logo

■ 1. Red Letters .....	1902
■ 2. Black Letters .....	0020

## 82014-30 Bernina Machine

■ 1. Single Color Design .....	4174
--------------------------------	------

## 82014-31 Classic Bernina Patch Appliqué

■ 1. Background Placement Stitch .....	1902
■ 2. Cut Line & Tackdown .....	1902
■ 3. Machine Placement Stitch .....	0020
■ 4. Cut Line & Tackdown .....	0020
■ 5. Machine Cover Stitch .....	0020
■ 6. Light Charcoal Shading .....	0132
■ 7. Gray Highlight .....	3274
■ 8. Silver Detail .....	3971
■ 9. Black Detail .....	0020
□ 10. White Detail .....	0015
■ 11. Dark Silver Detail .....	0131
■ 12. Light Gray Machine Detail .....	3770
■ 13. Red Detail .....	1902
□ 14. Letters & Linework .....	0015
■ 15. Background Cover Stitch .....	1902

## 82014-32 Bernina Love Pincushion

■ 1. Background & Fold Placement Lines .....	0020
■ 2. Background Tackdown .....	0020
■ 3. Black Detail .....	0020
■ 4. Red Detail .....	1902
■ 5. Seam .....	0020

## 82014-33 Bernina Repeat Logo

■ 1. Single Color Design .....	1902
--------------------------------	------

## 82014-34 Presser Foot FSL

■ 1. Single Color Design .....	0131
--------------------------------	------

## 82014-35 830 Record FSL

□ 1. White Detail .....	0015
■ 2. Dark Silver Detail .....	0131
■ 3. Dark Gray Detail and Cover Stitch .....	0112
■ 4. Black Letters .....	0020

## 82014-36 Bernina FSL

■ 1. Inside Letters .....	1902
□ 2. Candlewicking .....	0015
■ 3. Design Outlines .....	1902

## 82014-37 Bobbin FSL

■ 1. Single Color Design .....	0131
--------------------------------	------

## 82014-38 105

■ 1. Brown Detail .....	0862
■ 2. Dark Charcoal Detail .....	1375
■ 3. Brown Detail .....	0862
■ 4. Off White Detail .....	0870

## 82014-39 580 Appliqué

□ 1. Machine Placement Stitch .....	0015
□ 2. Cut Line & Tackdown .....	0015
□ 3. White Cover Stitch .....	0015
■ 4. Panel Placement Stitch .....	0020
■ 5. Cut Line & Tackdown .....	0020
■ 6. Dark Gray Linework .....	0132
■ 7. Panel Cover Stitch .....	0020
■ 8. Screen Placement Stitch .....	3815
■ 9. Cut Line & Tackdown .....	3815
■ 10. Screen Cover Stitch .....	3815
■ 11. Dark Silver Detail .....	0131
■ 12. Gray Detail .....	3274
■ 13. Red Letters & Linework .....	1902
■ 14. Button .....	5912

## 82014-40 730 Appliqué

■ 1. Side Knob Placement Stitch .....	0020
■ 2. Cut Line & Tackdown .....	0020
■ 3. Side Knob Cover Stitch & Detail .....	0020
□ 4. Machine Placement Stitch .....	0015
□ 5. Cut Line & Tackdown .....	0015
■ 6. Green Detail .....	5531
□ 7. Machine Cover Stitch .....	0015
■ 8. Black Lines & Detail .....	0020
■ 9. Front Knobs & Sign .....	0020
■ 10. Gray Detail .....	3274
■ 11. Red Detail .....	1902
■ 12. Light Gray Needle .....	0131
□ 13. White Detail & Letters .....	0015

## 82014-41 105 with Mountain

■ 1. Yellow Background .....	0504
■ 2. Blue Background .....	4430
■ 3. Medium Gray Mountain Detail .....	0131
■ 4. Light Charcoal Mountain Detail .....	0132
■ 5. Silver Mountain Detail .....	3971
□ 6. White Mountain Detail .....	0015
■ 7. Red Machine .....	1911
■ 8. Dark Red Shading .....	1921
■ 9. Bright Red Machine Detail .....	1805
□ 10. Letters .....	0015

## 82014-42 Swiss Heritage

□ 1. Light Blue Center .....	4071
■ 2. Dark Gray Mountain .....	0138
■ 3. Gray Mountain .....	3274
■ 4. Silver Mountain .....	3971
□ 5. White Mountain .....	0015
■ 6. Red Detail .....	1902
□ 7. White Cross .....	0015

## 82014-43 Sew Like A Rock Star

□ 1. Single Color Design .....	0015
--------------------------------	------

**NOTE: Paint colors listed refer to Fabrico Fabric Pens using the bullet tip. The number is the recommended pen color.**

## 82014-44\_PW BERNINA Made to Create

### PaintWork

■ 1. Fabrico Bullet Tip (Poppy Red) .....	# 114
■ 2. Fabrico Bullet Tip (Real Black) .....	# 182

## 82014-45\_CR BERNINA CrystalWork

■ 1. Size SS6 (105 Rhinestones) .....	Crystal
---------------------------------------	---------

### CRYSTALWORK INSTRUCTIONS:

1. Remove upper thread from the machine.
2. Attach the Straight Stitch/CutWork Stitch Plate for your machine.
3. Remove the needle and replace with the correct size punch tool (SS6, SS10, SS12, SS16 as noted on the Color Bar of the machine or in the crystal chart for the design collection) with the flat side toward the back. Tighten the needle clamp.
4. Attach Presser Foot #48.
5. Place the CrystalWork container on the stitch plate with the center positioning pin in the rear hole of the stitch plate.
6. Attach the punch plate (same size as the punch tool used) on top of the container so that it sits flush with the top.
7. Lower the punch tool by turning the handwheel to check that the container lines up correctly. **See Photo 1**
8. Hoop parchment paper up-side down and trim all excess from edges. **See Photos 2 and 3**
9. Cut a piece of rhinestone template material slightly larger than the design. Remove backing from the template material and place the sticky side down on the top of the parchment paper in the center of the hoop. **See Photo 4**
10. Place hoop on machine and use your machine's check feature to ensure that the template material is positioned correctly. Punch the first color change.

**Note:** The machine will prompt you when the container is full and needs to be emptied. However, you may also wish to empty the container between color changes. ANY time you remove the container for cleaning, be sure to repeat Step 7 to ensure that the container is positioned properly. Check the back of the parchment paper between color changes also to remove any stray dots that may be stuck to the paper.

11. If more than one size crystal is used in the design, replace the punch tool and the punch plate on the top of the container with sizes to correspond with the size shown on the Color Bar of the machine. Repeat this process as needed until the design is finished. **See Photo 5**
12. Carefully peel the rhinestone template material away from the parchment paper and place on a piece of rhinestone template backboard. Smooth into place.
13. Pour the largest size of crystals used in the design over the template and use a small rhinestone brush to push them into place. **See Photos 6 and 7**
14. Make sure that all holes of that size are filled, and that all crystals are facing upright.
15. Repeat Steps 13 and 14 for any additional sizes, continuing with the next largest size and progressing to the smallest size.
16. Once all holes in the template are filled with the correct size crystals, check to ensure that all crystals are facing up and that there are no stray crystals. **See Photo 8**

**Note: Design pictured is for instructional purposes and is not included in this collection.**

It is a violation of Copyright law to make and distribute copies of instructions or artwork. Electronic designs are licensed to the original purchaser for use at one location. ©2015 OESD, LLC. All rights reserved.

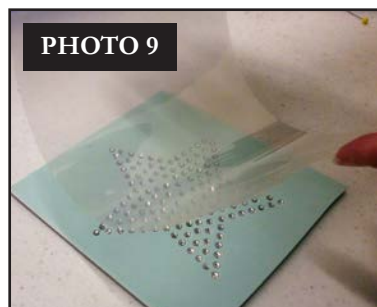
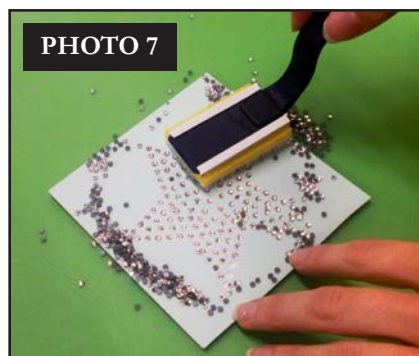
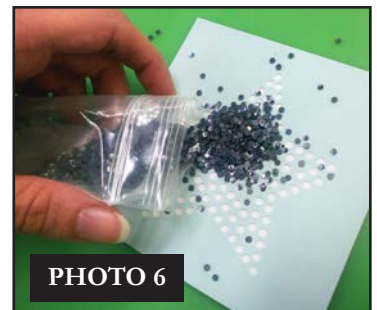
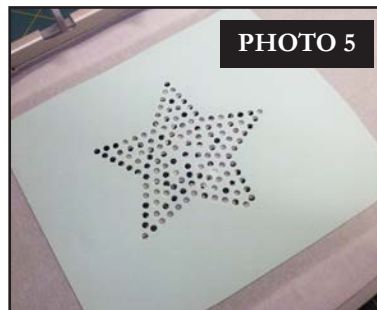



17. Cut a piece of rhinestone application tape slightly larger than the design.
18. Remove the backing and place tape sticky side down over the crystal template. **See Photo 9**
19. Smooth application tape over the top of each crystal using your fingertips or the rhinestone brush to ensure that all crystals are adhered to the tape.
20. Slowly peel transfer tape away from the template. The crystals should come up adhered to the tape. **See Photo 10** If individual crystals are loose or missing, lay the tape carefully back down and re-adhere crystals.
21. Position the transfer tape with the crystals sticky side down onto your project. **See Photo 11**
22. Place a press cloth over the transfer tape and press firmly with a hot iron for approximately 15 seconds. If the transfer is larger than the iron, move the iron to another area and repeat. **Note:** Time and temperature given here are meant as guidelines only. Refer to instructions from the crystal manufacturer for best results.
23. Allow the transfer to cool completely before peeling the transfer tape away. **See Photo 12**

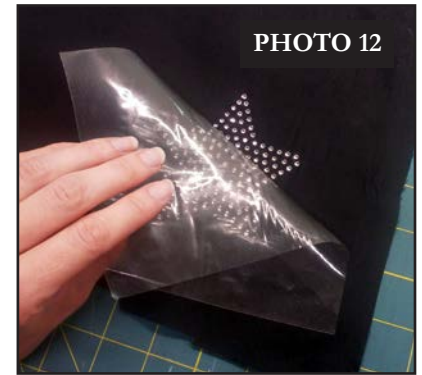

### PAINTWORK INSTRUCTIONS

1. Remove the upper thread and needle from the machine.
2. Attach the Straight Stitch/CutWork Stitch Plate to the machine.
3. Open the clamping lever on the PaintWork tool and slide the appropriate pen adaptor into the shaft of the tool. Close the clamping lever.
4. Attach the PaintWork tool over the presser foot holder cone and secure with the lever.
5. Prior to hooping, iron the fabric to remove any wrinkles. The fabric must be smooth and hooped securely in order to ensure proper working of the tool.
6. Hoop your project using the appropriate stabilizing method.

#### Method A:

- a. Hoop a piece of Stabil-Stick Cut Away or Stabil-Stick Tear Away by itself in the hoop.
- b. Score and remove the paper.
- c. Place the fabric to be painted over the sticky surface with right side up. Gently smooth into position. For best results, the stabilizer should be adhered to as much area of the fabric as possible.

#### Method B

- a. Spray stabilizer of your choice with a generous amount of temporary spray adhesive.
  - b. Place the sprayed side of the stabilizer on the wrong side of the fabric. Hoop all layers as one unit.
7. Attach the hoop to the machine.
  8. Swing the pen guard down. Release the clamping lever and insert the appropriate pen with a slight twisting motion until the tip just touches the pen guard. Close the clamping lever. The pen should now be held firmly in place. **NOTE:** Although there should be some pressure against the pen as it is inserted, do not use excessive force without supporting the PaintWork tool.
  9. Swing the pen guard up and start painting using the Start / Stop button on the machine. **NOTE:** It is advisable to hoop a test piece of fabric to test for pen pressure prior to the painting on the actual project. An alternative to this is to cut a hoop sized piece of Stabil-Stick, remove the paper from the entire back, and place the Stabil-Stick over the hooped project. Start the machine and paint for a few seconds. Adjust the pen pressure as needed to achieve the look you desire. (**See Photo 1**) Turning the dial counter-clockwise decreases the pressure. Turning the dial clockwise increases the pressure. When you have achieved the desired effect, remove the Stabil-Stick from the top and re-start the design from the beginning.
  10. When the first color is finished, swing the pen guard down. Open the clamping lever and remove the pen.
  11. Clean the pen guard between color changes and allow fabric to dry between color changes to avoid mixing colors. **Tip:** To help guarantee colors will not mix, remove the hoop from the machine, but not the fabric from the hoop. Use a small, applique iron to heat the color. Replace the hoop and continue your design.
  12. Refer to the color information on the machine's screen and insert a second pen following steps above if needed. **Tip:** after raising the pen guard, wipe the tip of the pen with a white cloth before starting the color. **See Photo 2**
  13. Use an Iron to heat set the painted fabric following pen manufacturer's instructions.

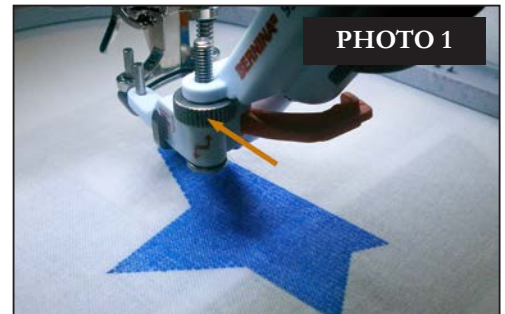

## Supplies

- 6" square fabric for pincushion front
- 6" x 6" and 6" x 8" rectangles for pincushion back
- Two 6" squares fabric for pincushion form
- OESD PolyMesh stabilizer (large enough to hoop, approximately 10" x 14")
- Isacord embroidery thread
- Temporary adhesive spray
- Point turning tool

1. Hoop a piece of PolyMesh stabilizer. Place on the machine and select the pincushion design. Stitch the first color change on the stabilizer. **IMAGE 01.**
2. Lightly spray the back of the 6" square of front fabric with temporary adhesive spray. Place onto the stabilizer, centering it over the square stitched on the stabilizer. Smooth into place. **IMAGE 02.**
3. Stitch the next color change, which is a basting stitch. **IMAGE 03.**
4. Stitch the third color change, the machine outline. **IMAGE 04.**
5. Stitch the fourth color change, "BERNINA" and the heart. **IMAGE 05.**
6. Fold and press the two back fabric pieces in half, wrong sides together, to form a 3" x 6" piece and a 4" x 6" piece. **IMAGE 06.**
7. Place the 3" x 6" piece onto the project, aligning the folded edge with the leftmost placement markings. **IMAGE 07.**
8. Place the 4" x 6" piece onto the project, aligning the folded edge with the rightmost placement markings. **IMAGE 08.**
9. Stitch the fifth color change, the seam stitch. **IMAGE 09.**
10. Remove the project from the hoop. **IMAGE 10.**
11. Trim the project, including stabilizer, to 1/4" from the seam line. **IMAGE 11.**

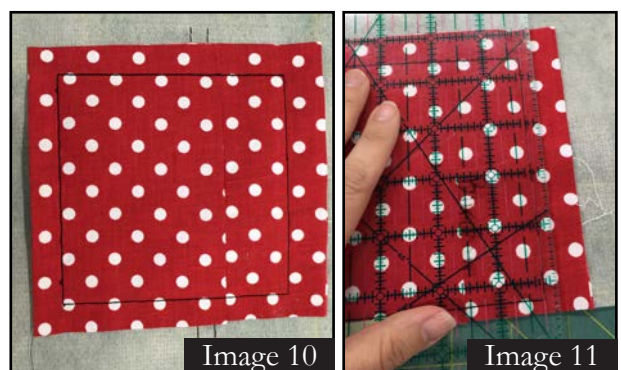
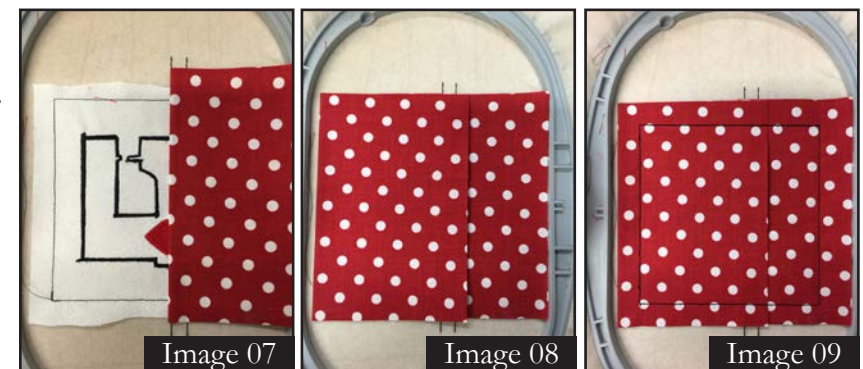
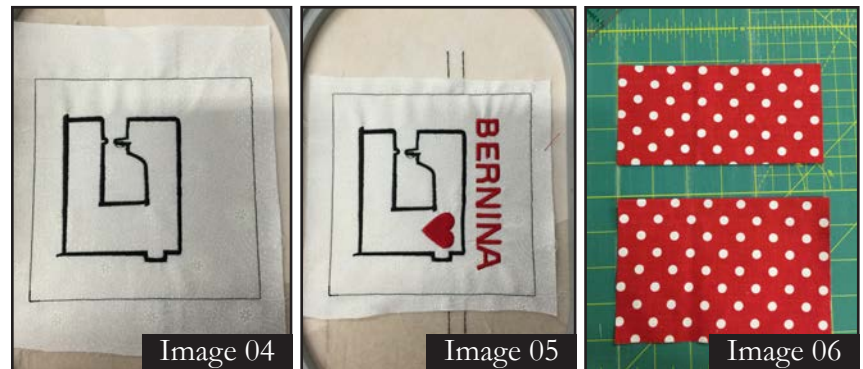
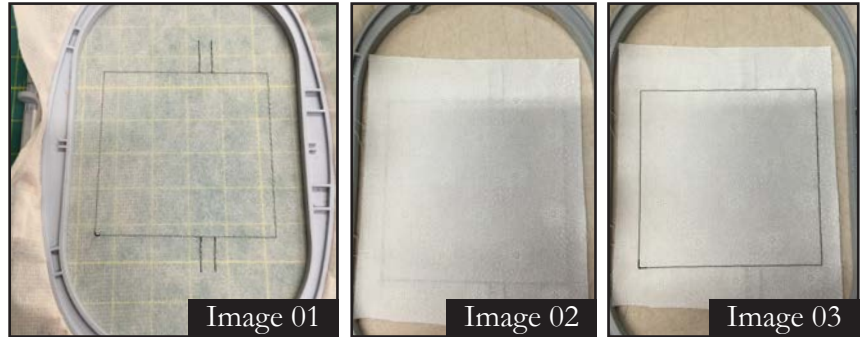



12. Turn the project through the opening between the back flaps. Use a point turning tool to turn out the corners. **IMAGE 12.**
13. Place the two 6" squares of pincushion form fabric right sides together. **IMAGE 13.**
14. Stitch around the square with a 1/2" seam, leaving a 2" opening for turning. **IMAGE 14.**
15. Turn the pincushion form right side out, stuff with walnut shells or stuffing, and stitch the opening closed. **IMAGE 15.**
16. Stuff the pincushion form into the pincushion project. **IMAGE 16.**
17. If desired, tack the two flaps together with a tack stitch. **IMAGE 17.**
18. Your pincushion is ready to use! **IMAGE 18.**



Image 12



Image 13



Image 14



Image 15



Image 16



Image 17

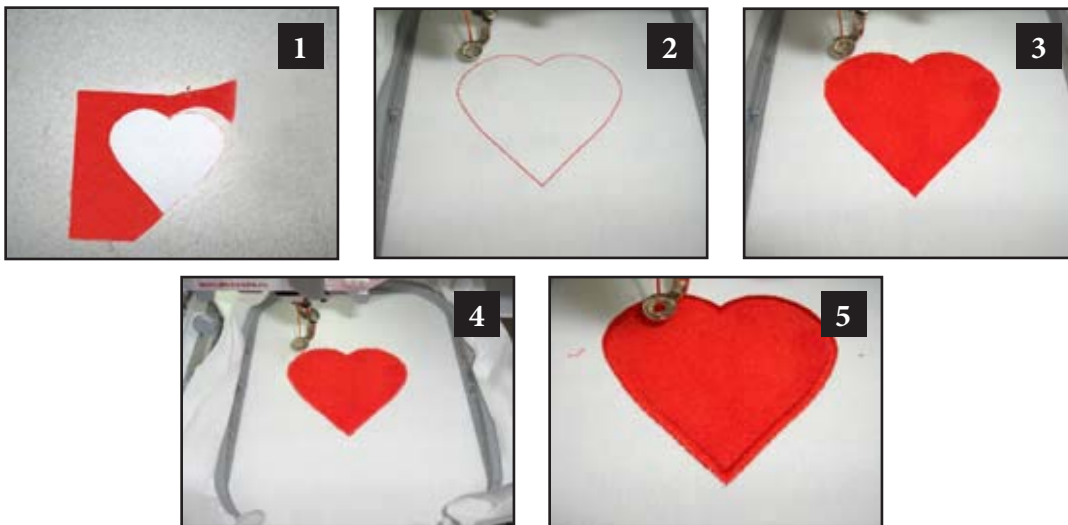

Image 18

1. Print out the necessary pages from the PDF of the appliqué pattern(s).
2. Mark the right side of the pattern pieces so you'll know which direction to lay the pattern on the fabric.
3. Lightly spray the wrong side of the pattern pieces with temporary adhesive spray and allow it to set for a few minutes.
4. Place the pattern pieces on the right side of the fabric and carefully cut them out. **PHOTO 1**
5. Sew the placement stitch on your hooped fabric. **PHOTO 2**
6. With the paper still stuck to the right side of the appliqué fabric, spray the wrong side of the fabric with temporary spray adhesive.
7. Place the fabric inside the sewing placement stitch so that it matches the stitching line, and then remove the paper pattern. **PHOTO 3**
8. Sew the tackdown. **PHOTO 4**
9. Sew the remainder of the design and repeat for any remaining pieces. **PHOTO 5**

**NOTE:** The patterns are sized for the designs as they were made. If you resize the design, you will need to resize the pattern the same amount. You can print out the pattern at the normal size then copy it on a copy machine at the changed size. For example, resize the designs to 80%, resize the printed pattern to 80%.

**TIP:** When Printing the patterns, make sure that the “Fit to page” option is **UNCHECKED** in the Print Dialog Box. If this option is checked the printed patterns will not be actual size.





### ATTENTION

When printing this document, any page scaling or page fitting options in your print dialog box must be turned OFF or set to NONE so that your files will print out at their actual size. Images not printed at actual size will not function as intended.

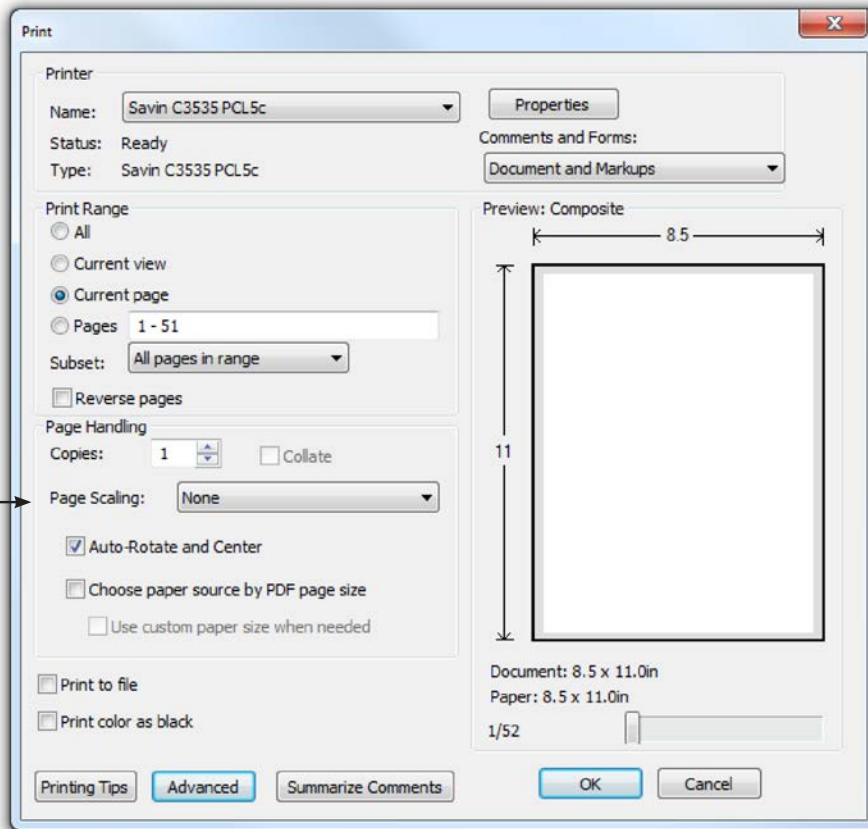

### TO SAVE PAPER

Only print the desired image by navigating to the image's page, go to File > Print and select "Current page" in the print dialog box. Repeat for each desired image.

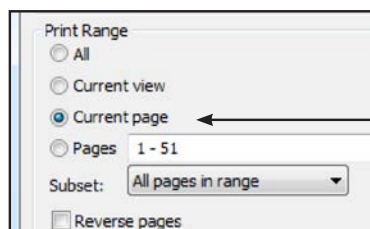

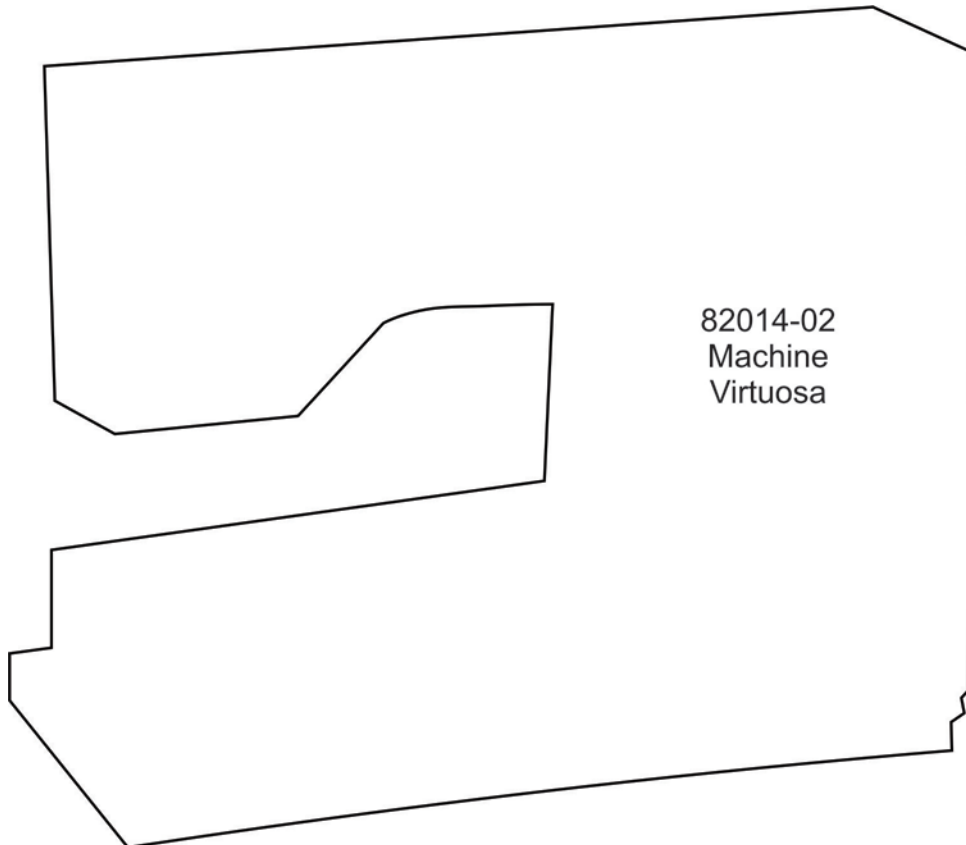
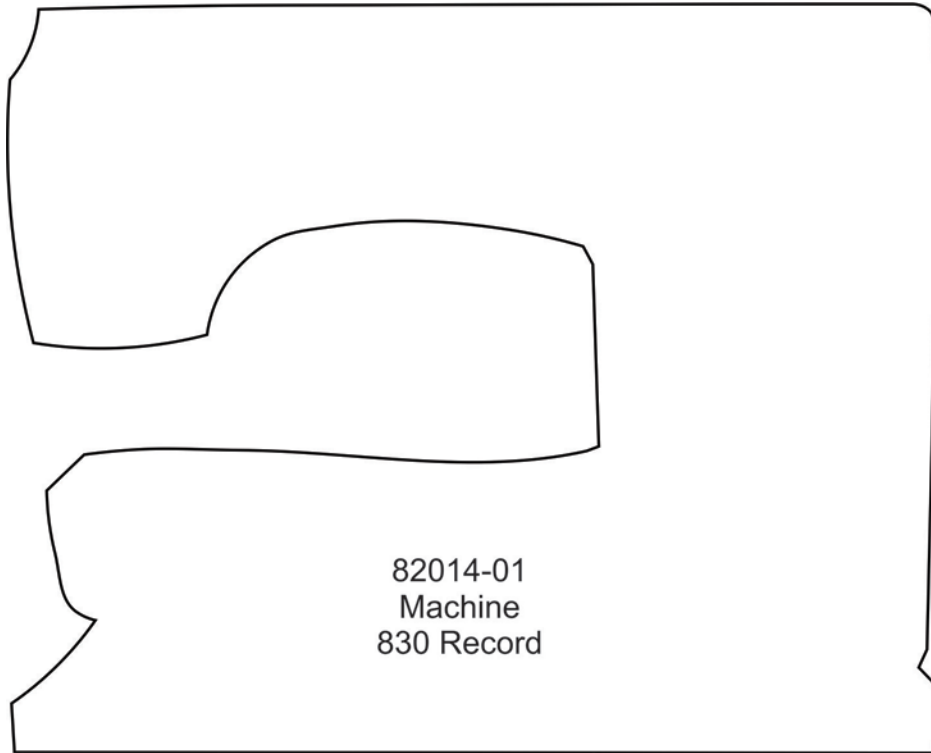



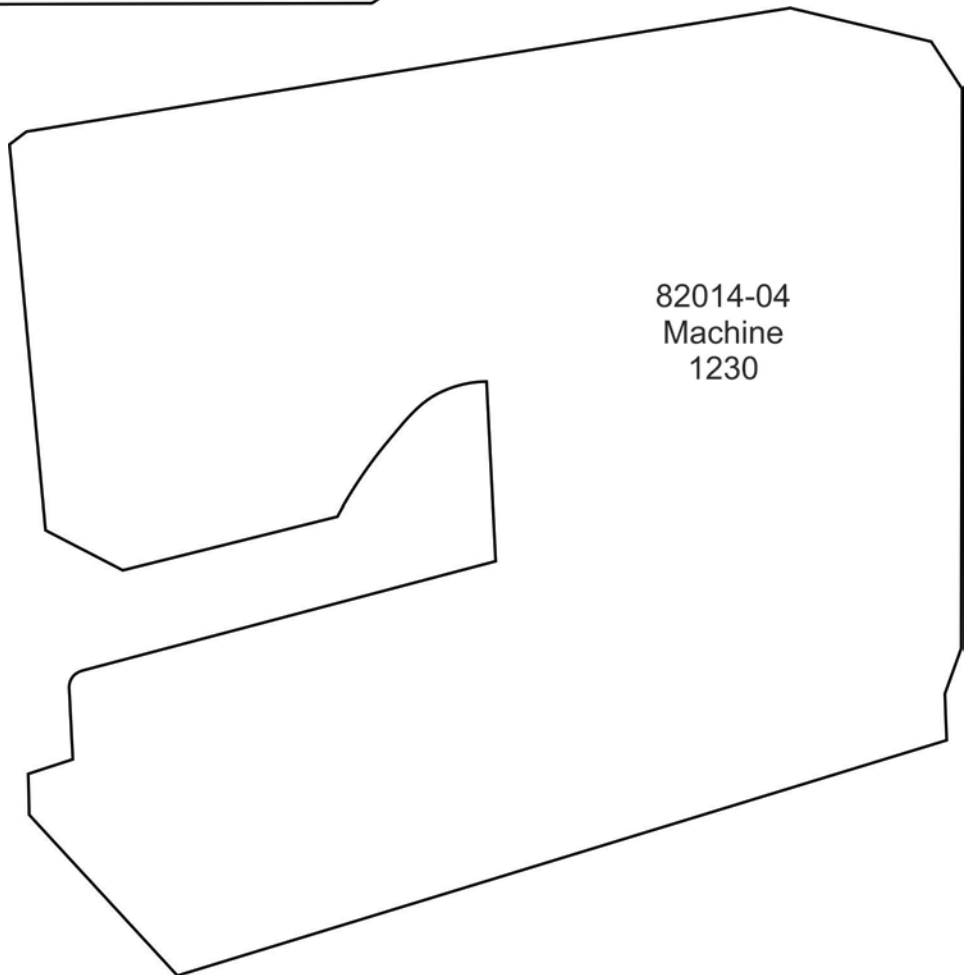
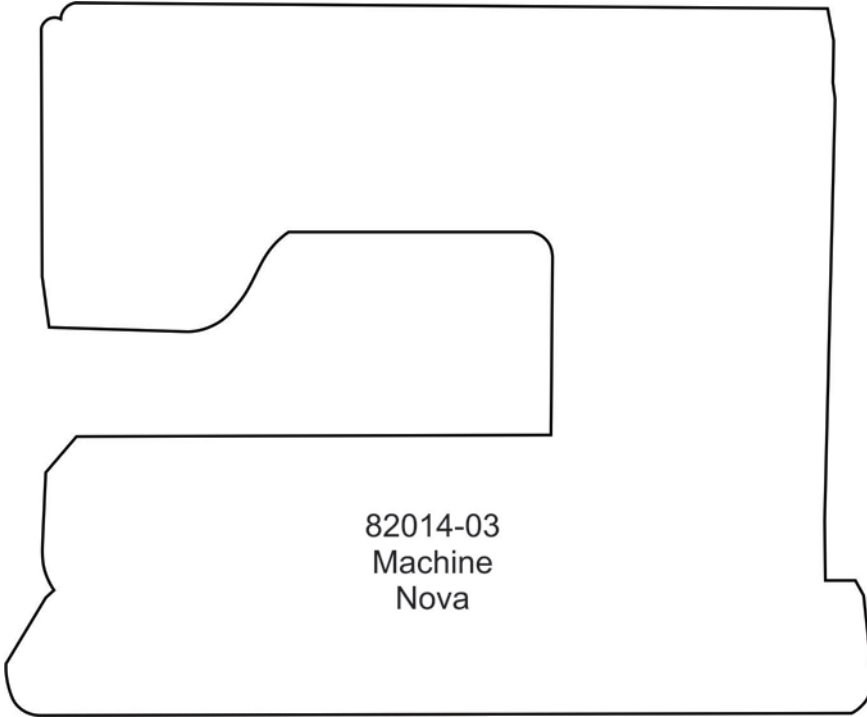

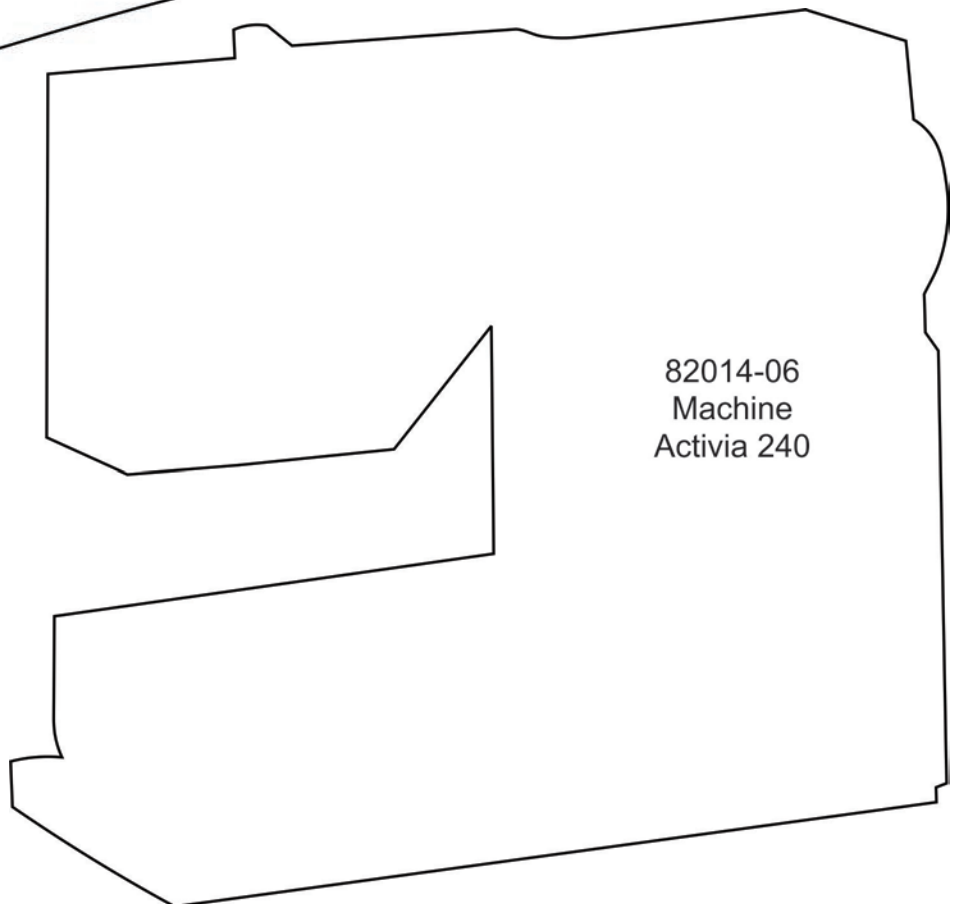
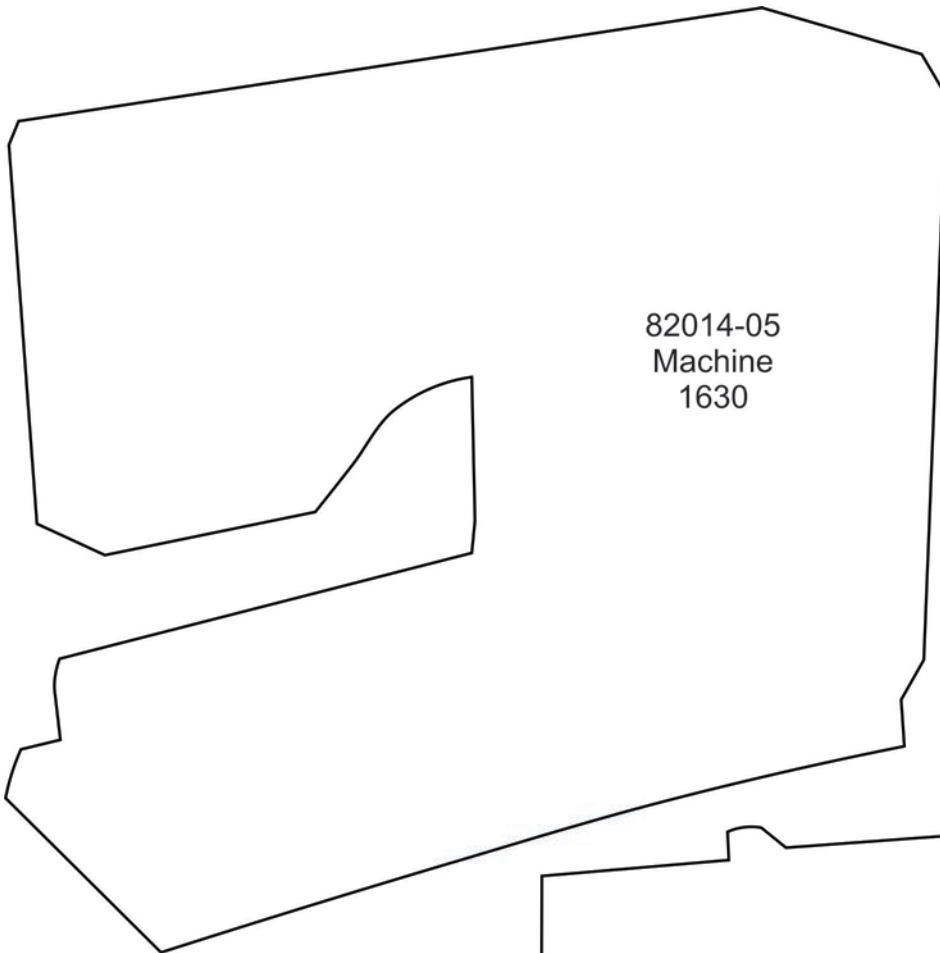



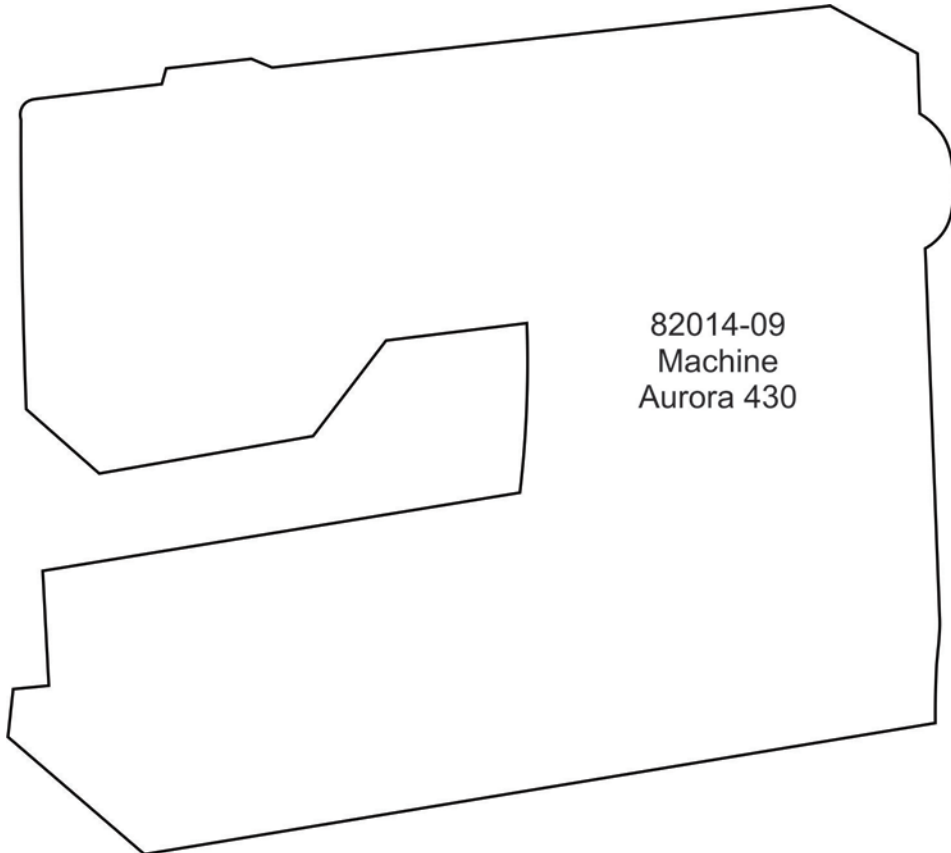
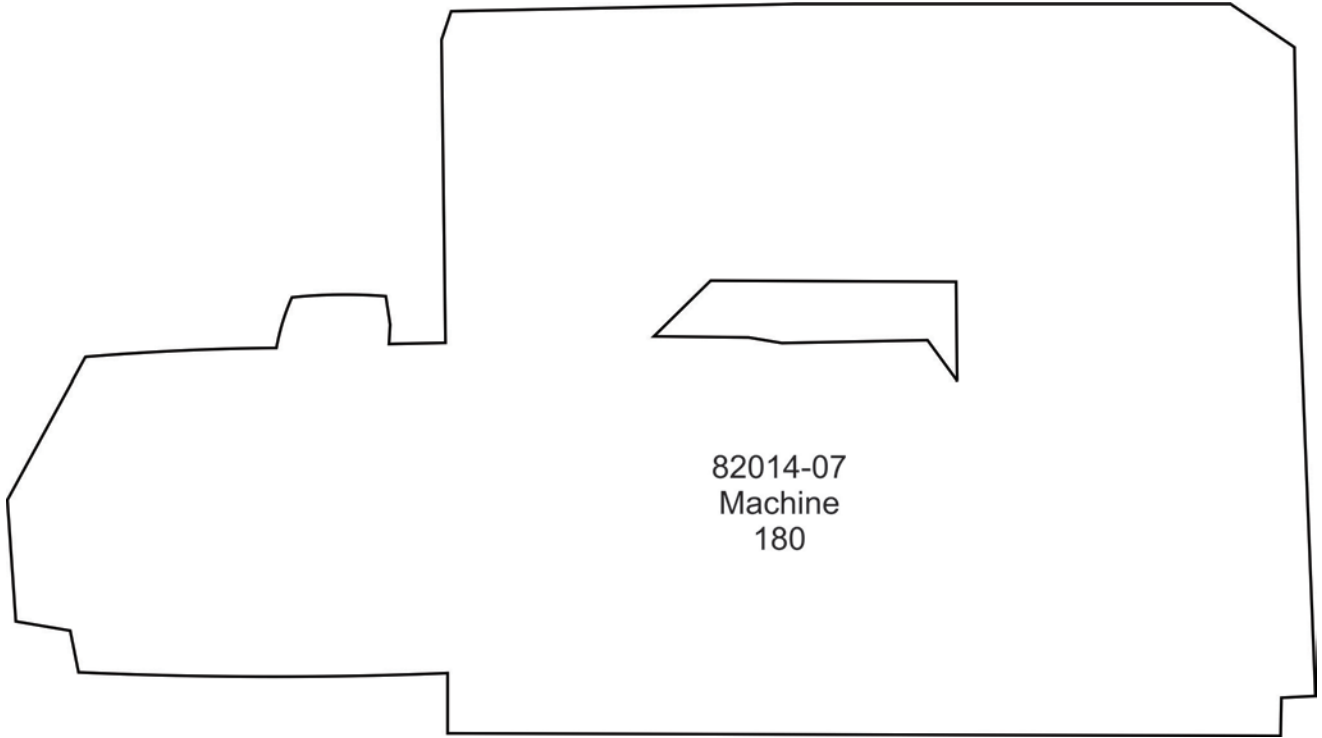

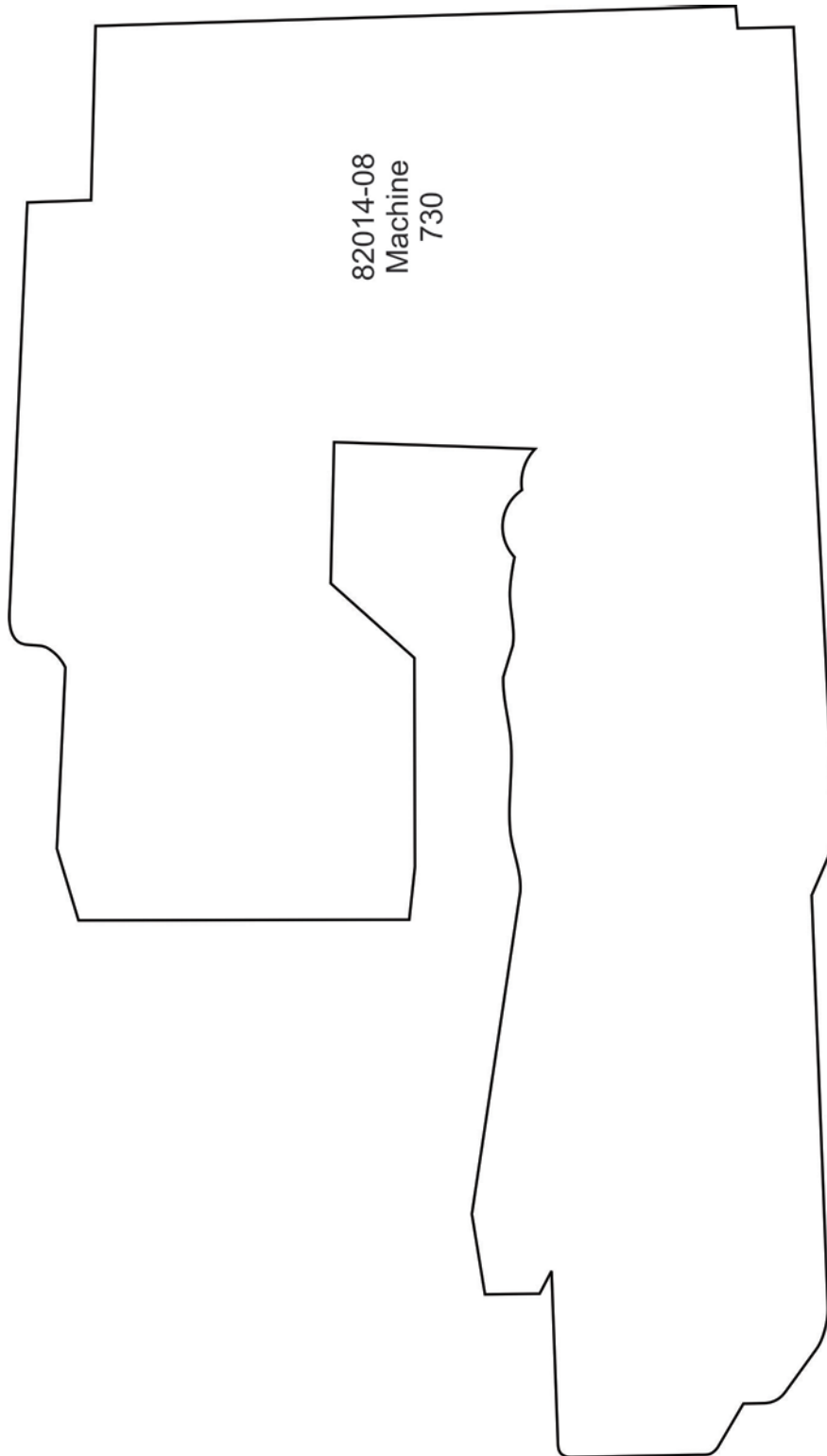



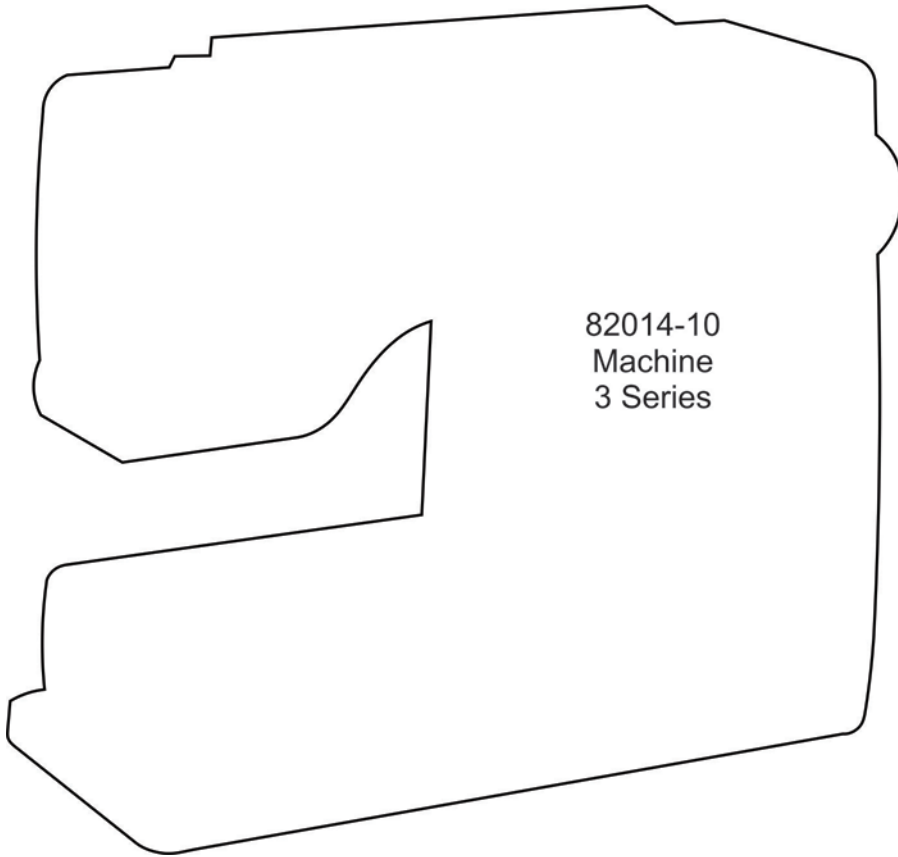

82014-10  
Machine  
3 Series

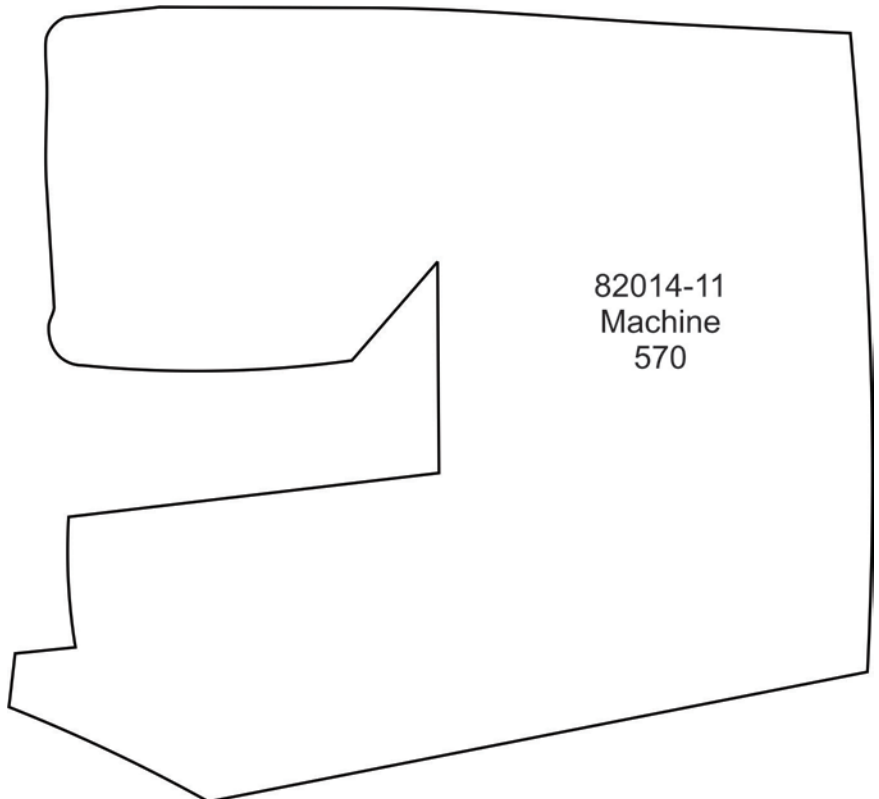

82014-11  
Machine  
570

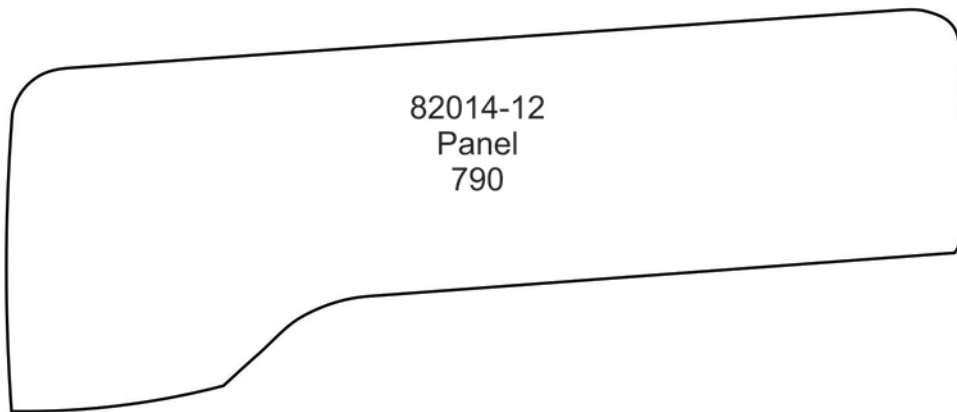
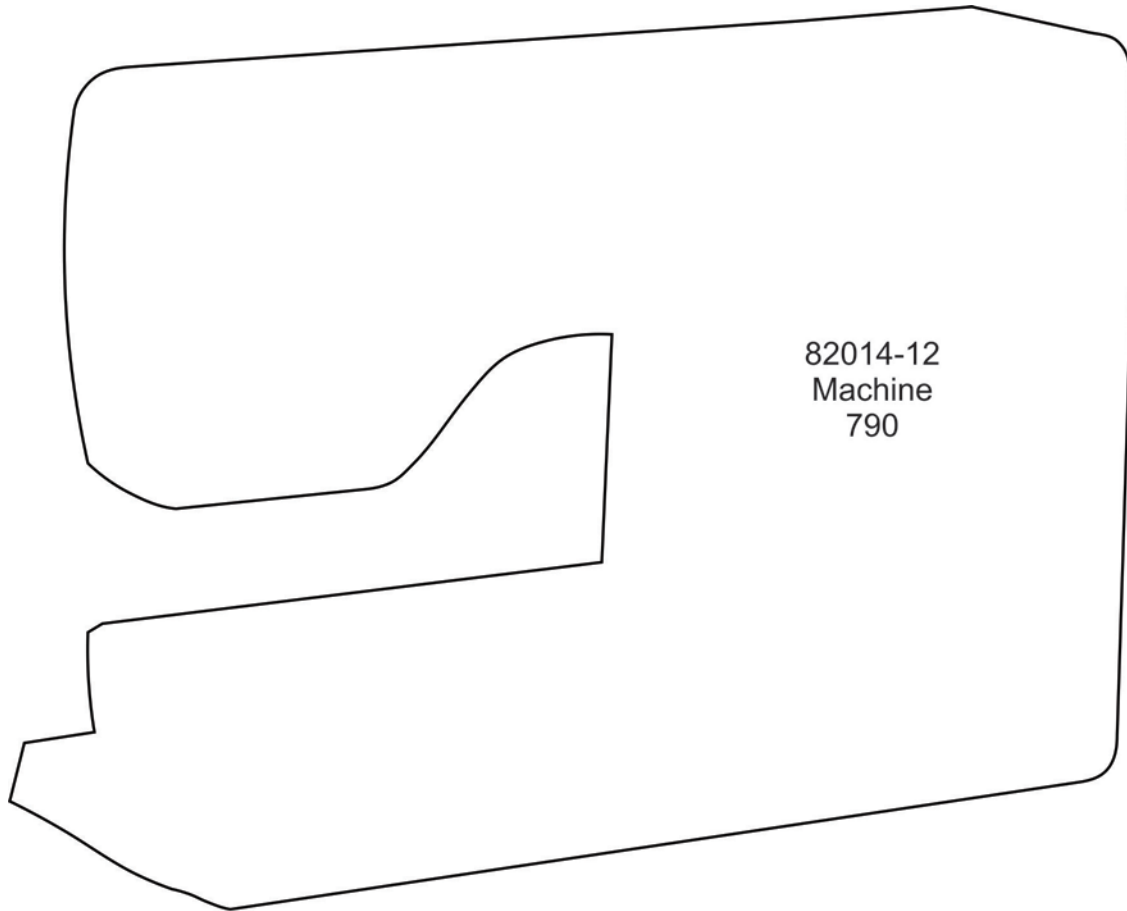



82014-13  
Machine  
880

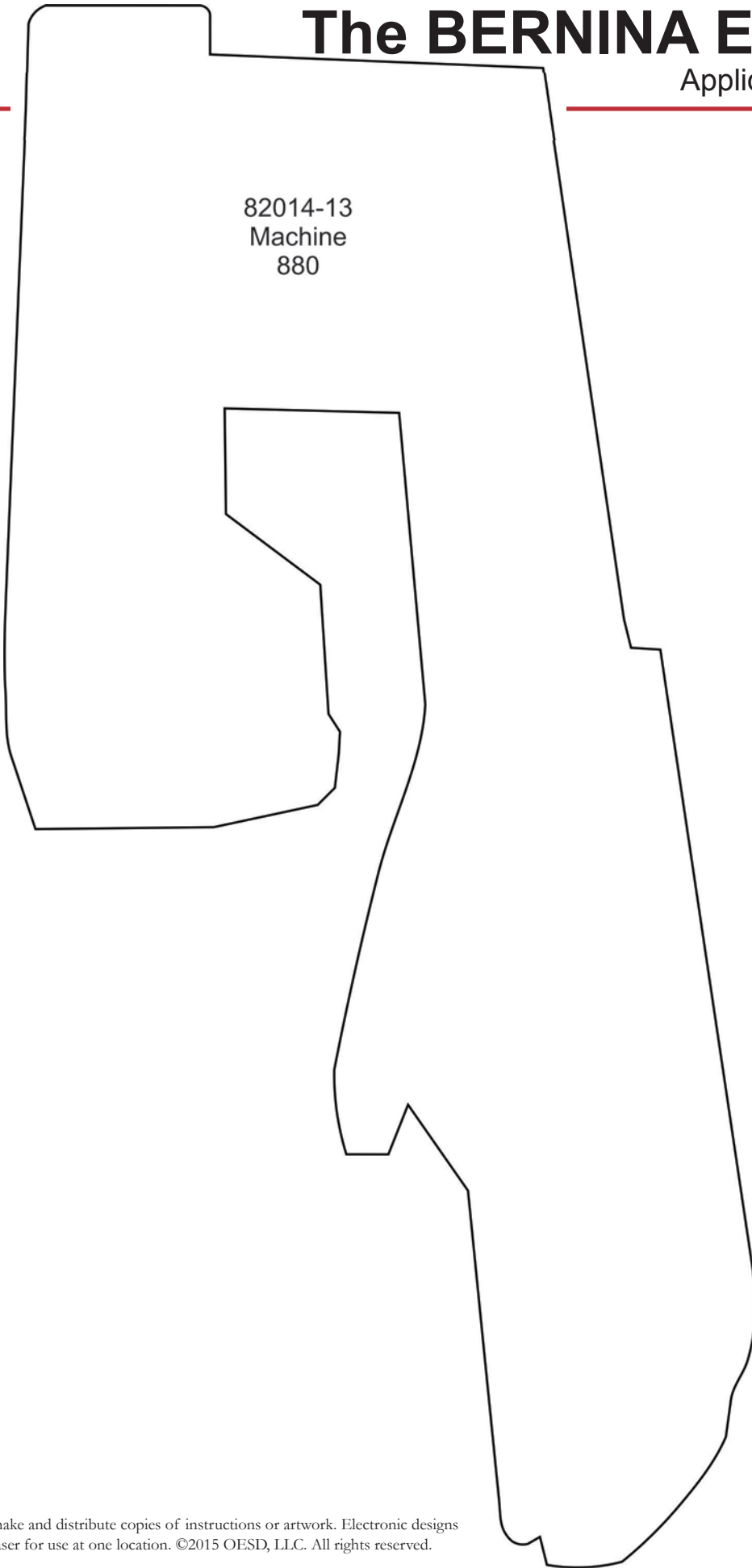

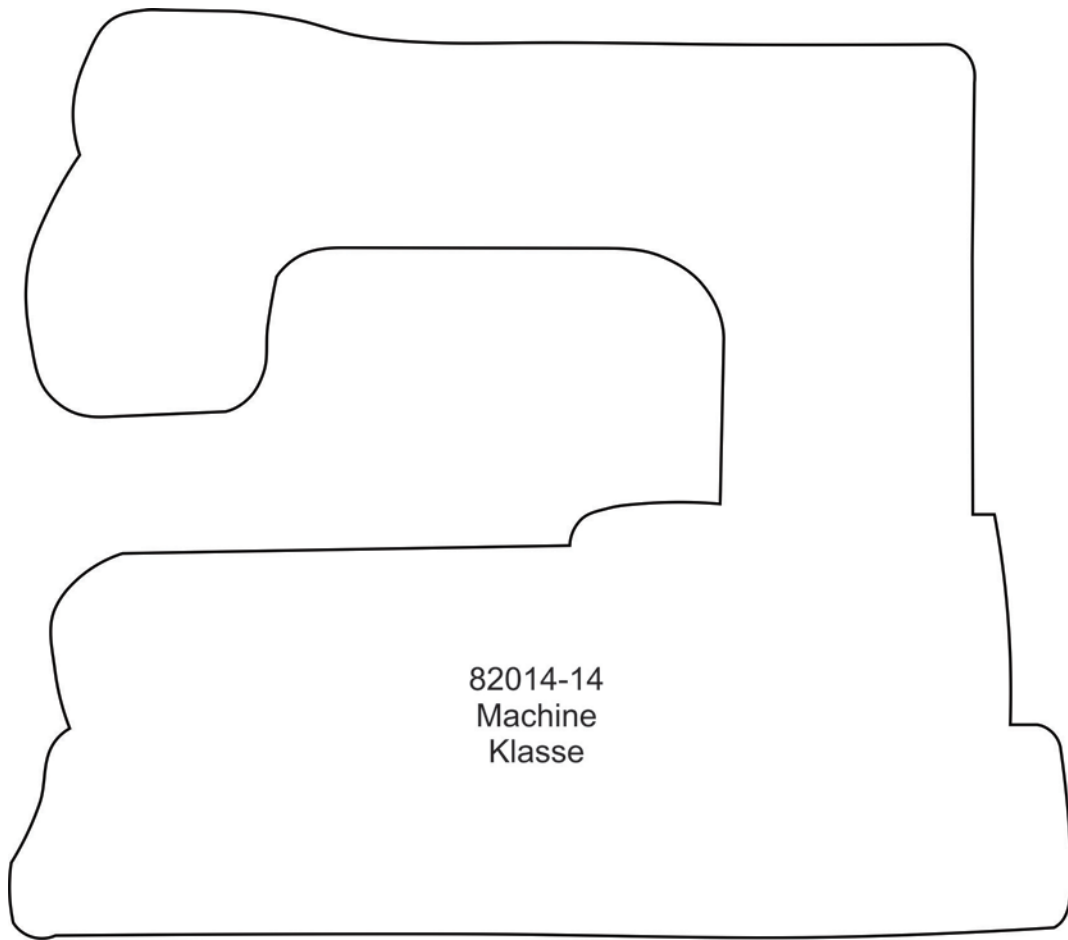

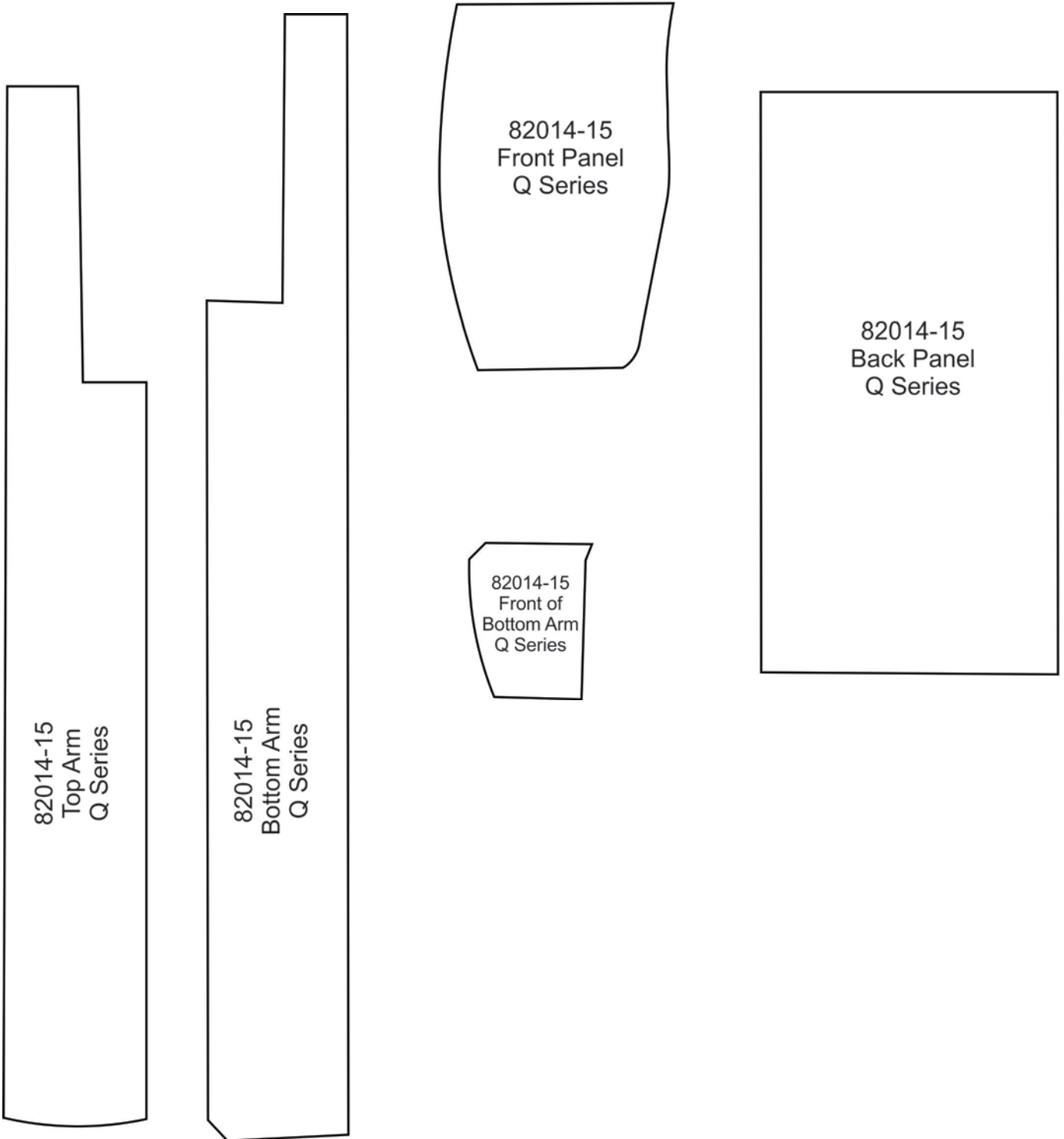



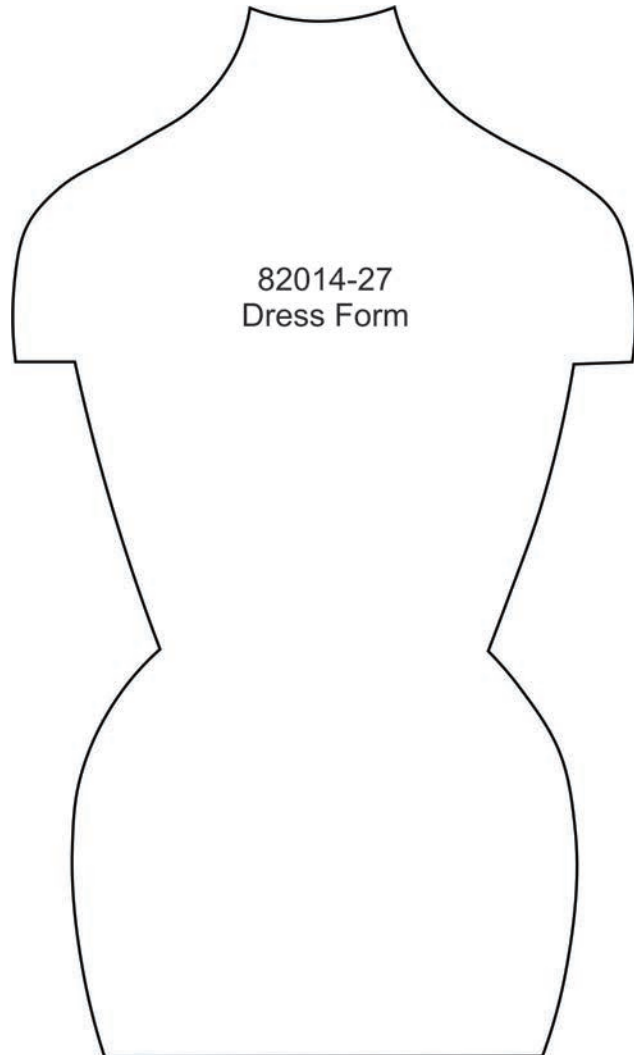
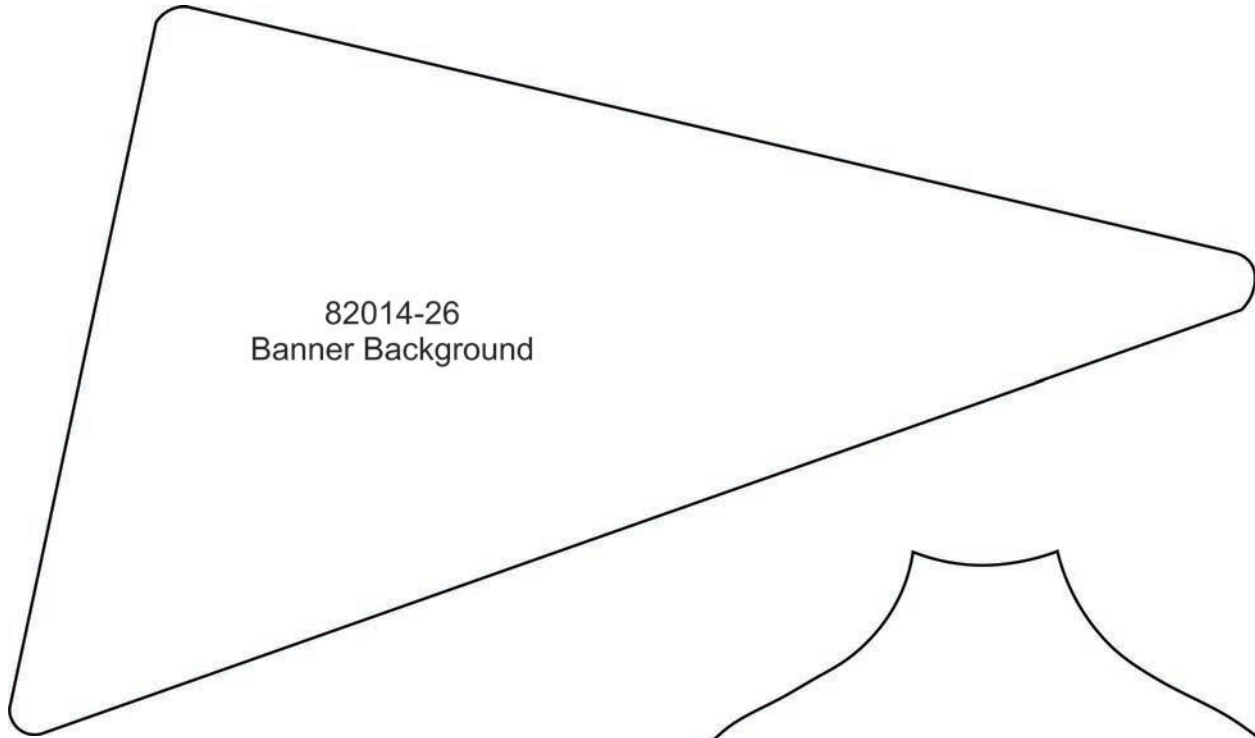

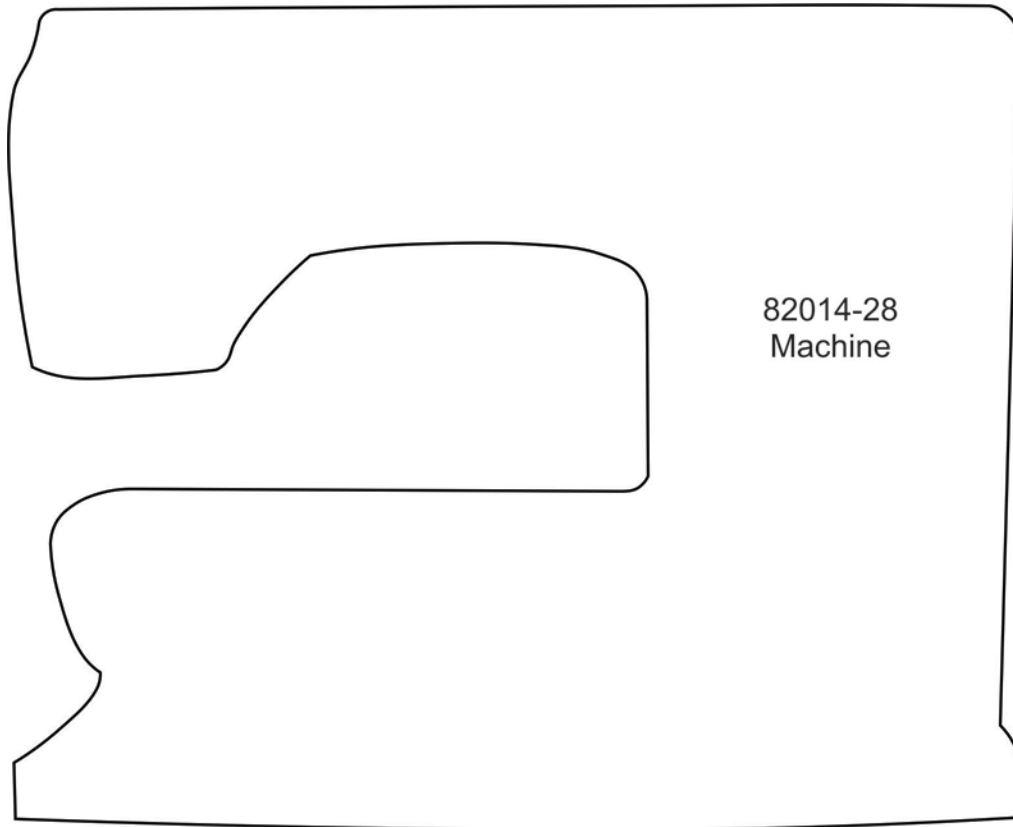

82014-28  
Machine

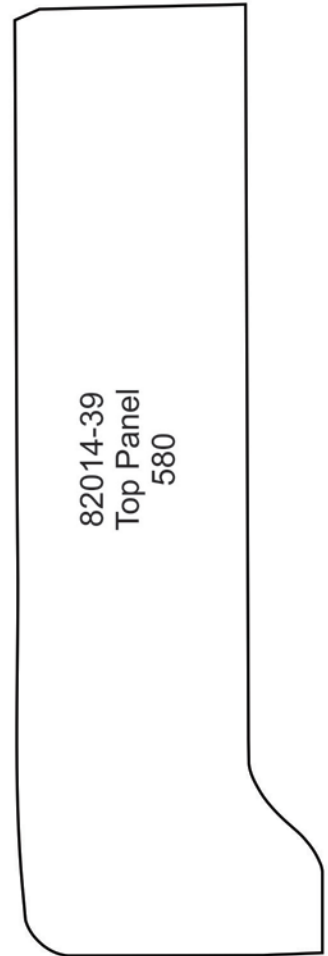

82014-39  
Top Panel  
580

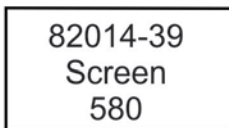

82014-39  
Screen  
580

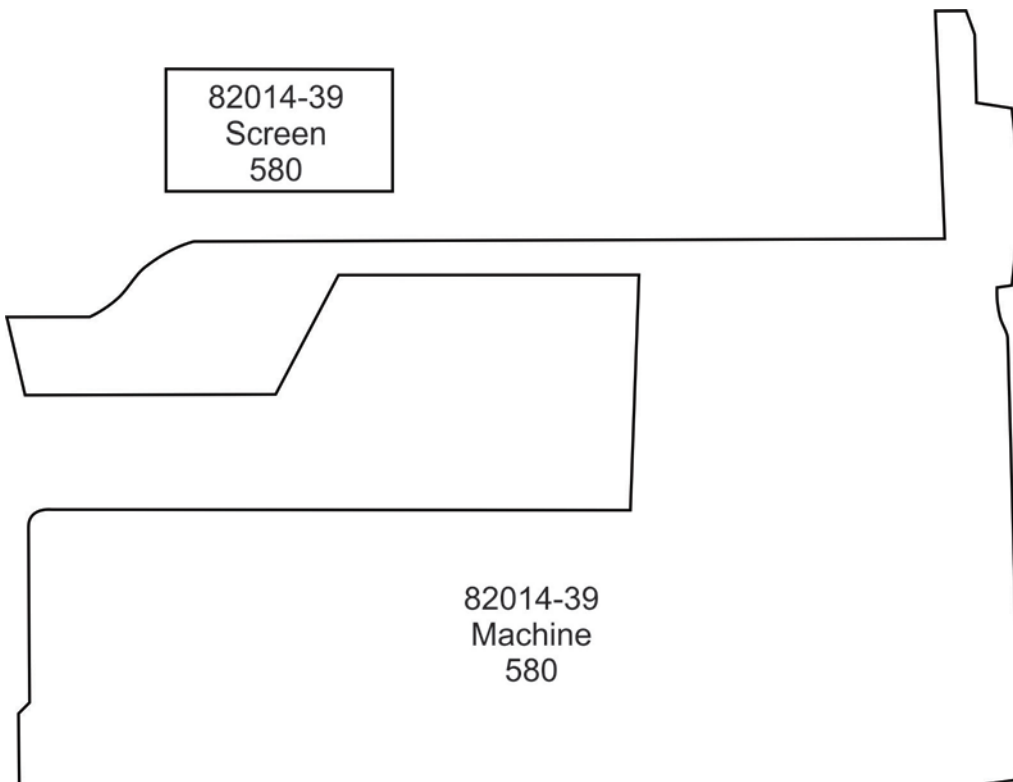

82014-39  
Machine  
580

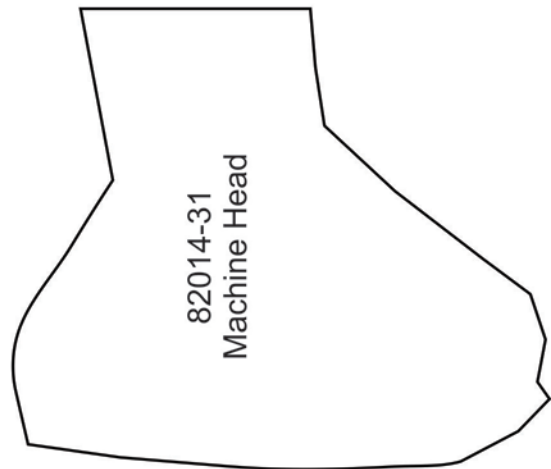
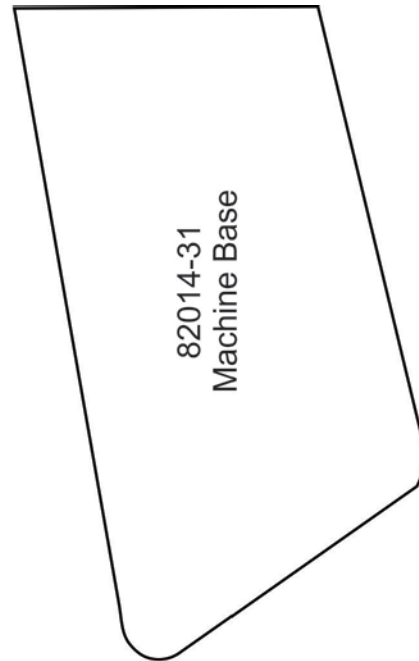
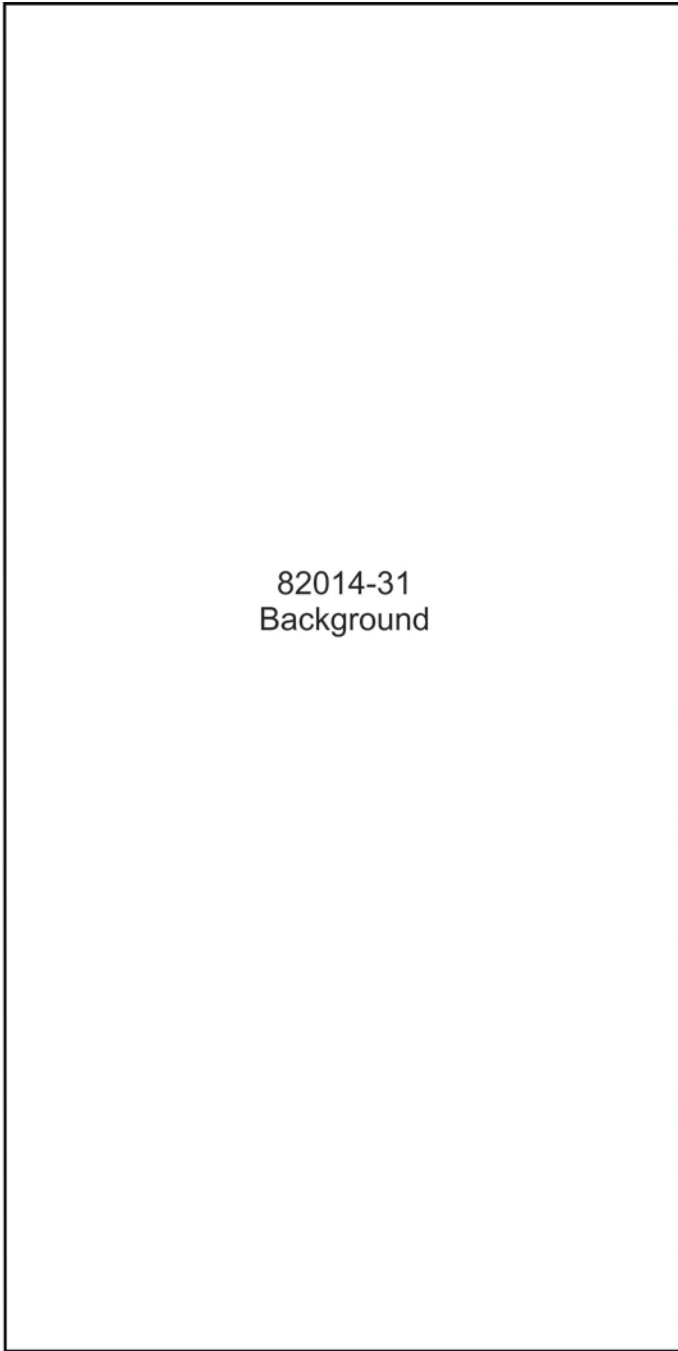



82014-40  
Side Knob  
730

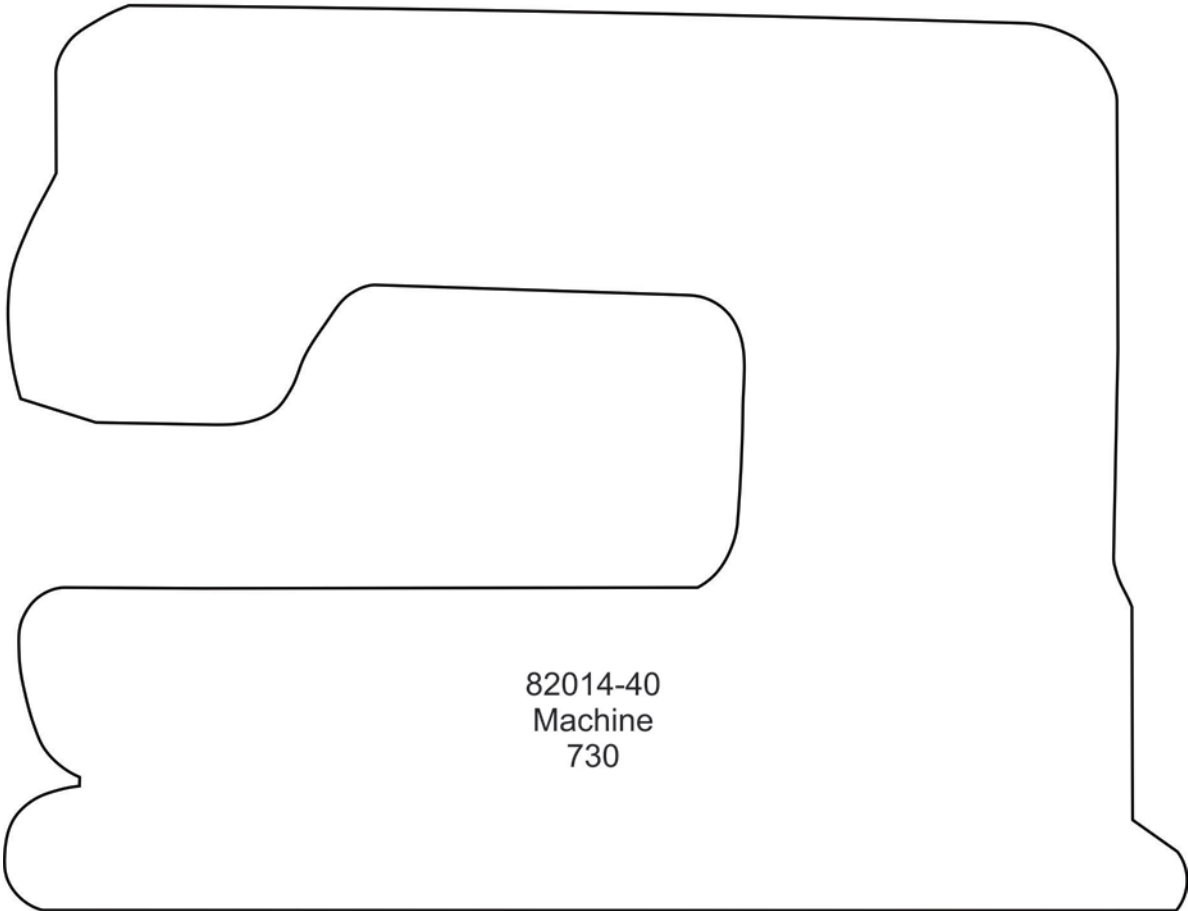

82014-40  
Machine  
730

OECD™